

MITOPENCOURSEWARE
MASSACHUSETTS INSTITUTE OF TECHNOLOGY

6.776

High Speed Communication Circuits and Systems

Lecture 16

Mixers, continued

Massachusetts Institute of Technology

April 5, 2005

**Copyright © 2005 by Hae-Seung Lee and Michael H.
Perrott**

Image Reject Mixer, Review

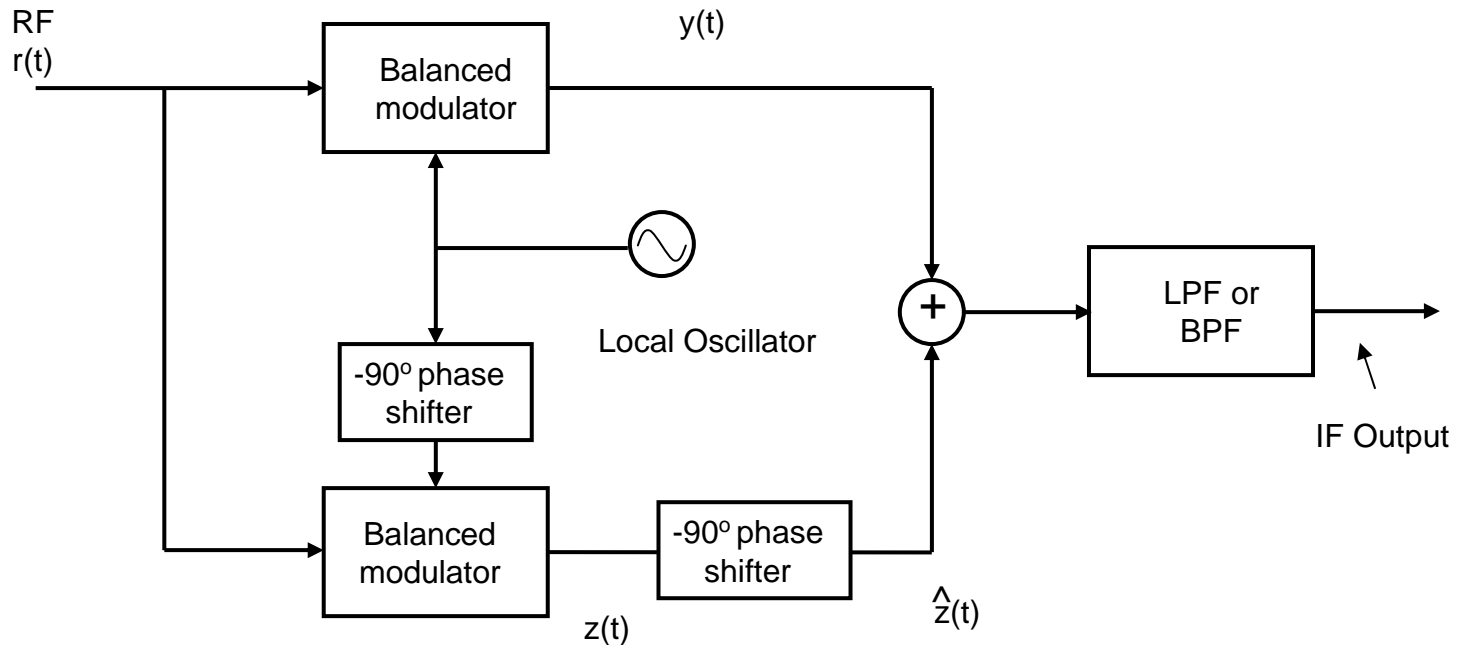

- **Rather than filtering out the image, we can cancel it out using an image rejection mixer**
 - **Advantages**
 - Allows a low IF frequency to be used without requiring a high Q filter
 - Very amenable to integration
 - **Disadvantage**
 - Level of image rejection is determined by mismatch in gain and phase different paths
 - Practical architectures limited to about 40 dB image rejection

Image Reject Mixer, Alternate Implementation

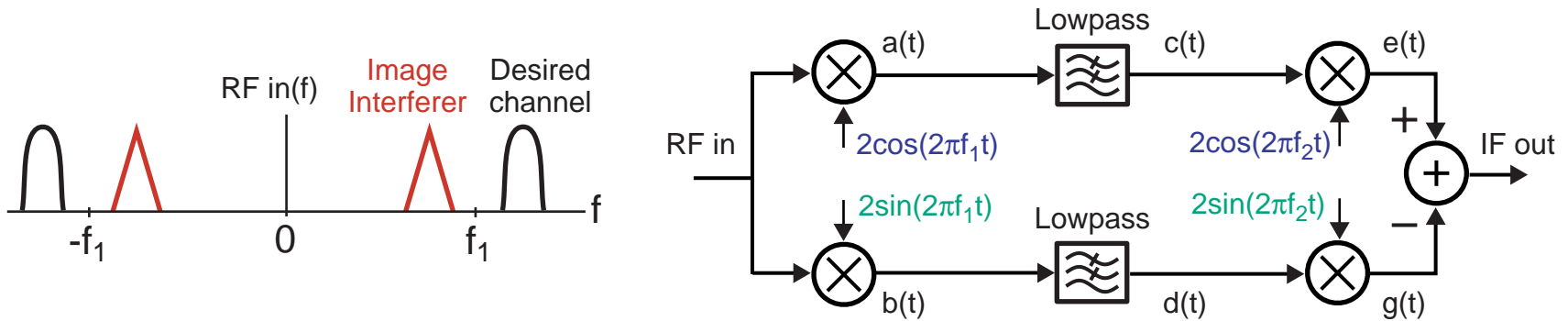

- Avoids 90 degree phase shift of signal
- Precise 90 degree phase shift of LO outputs is much easier by using quadrature VCO's or frequency dividers

Image Reject Mixer Principles – Step 1

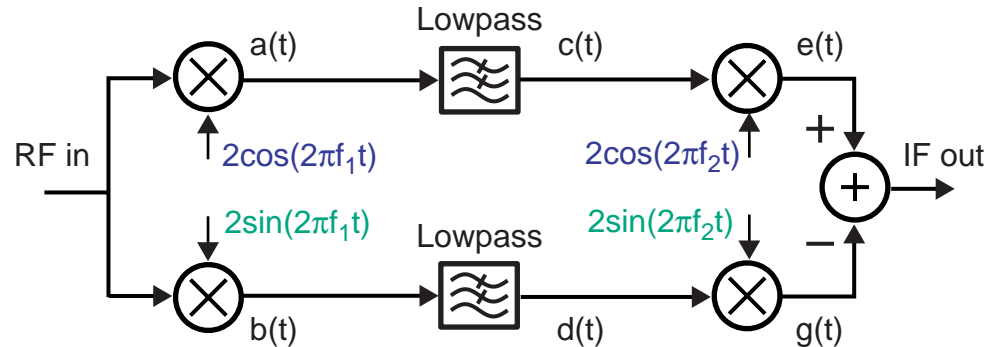
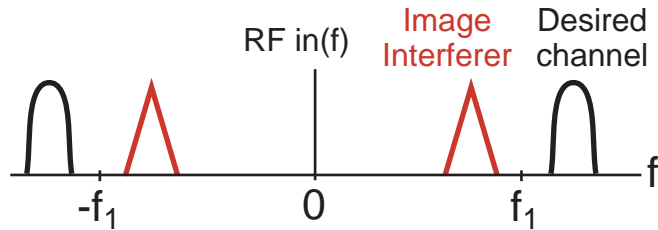

- Note: we are assuming RF in(f) is purely real right now

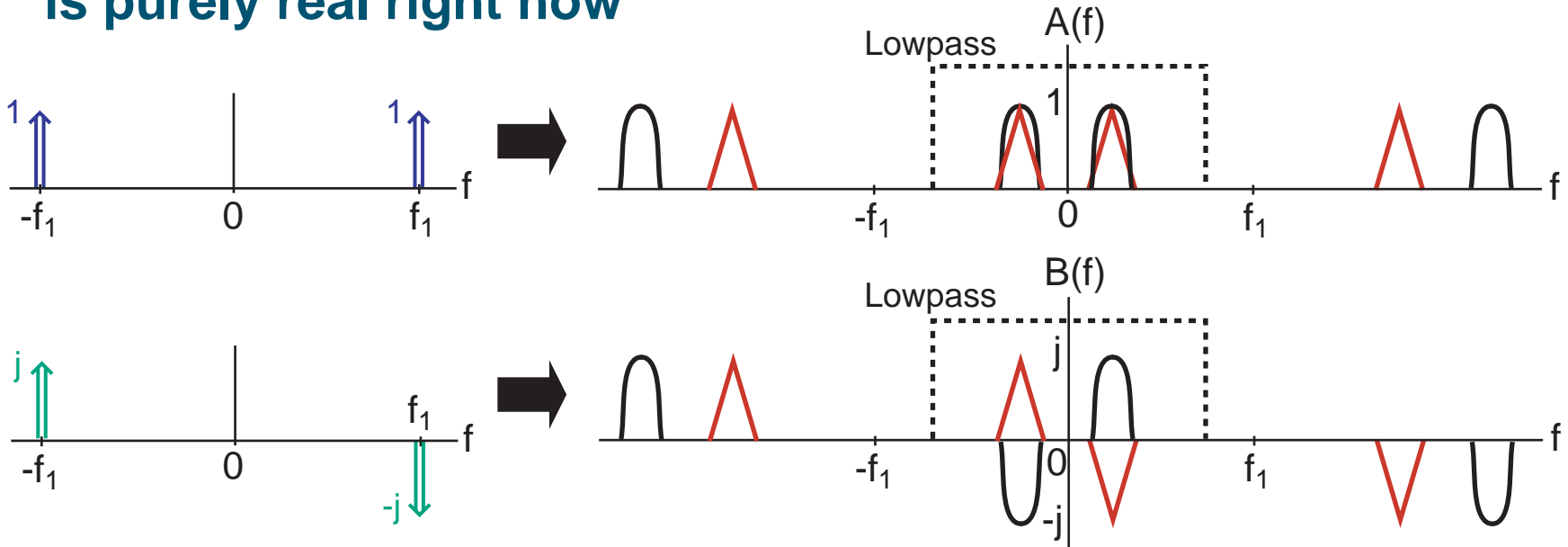

Image Reject Mixer Principles – Step 2

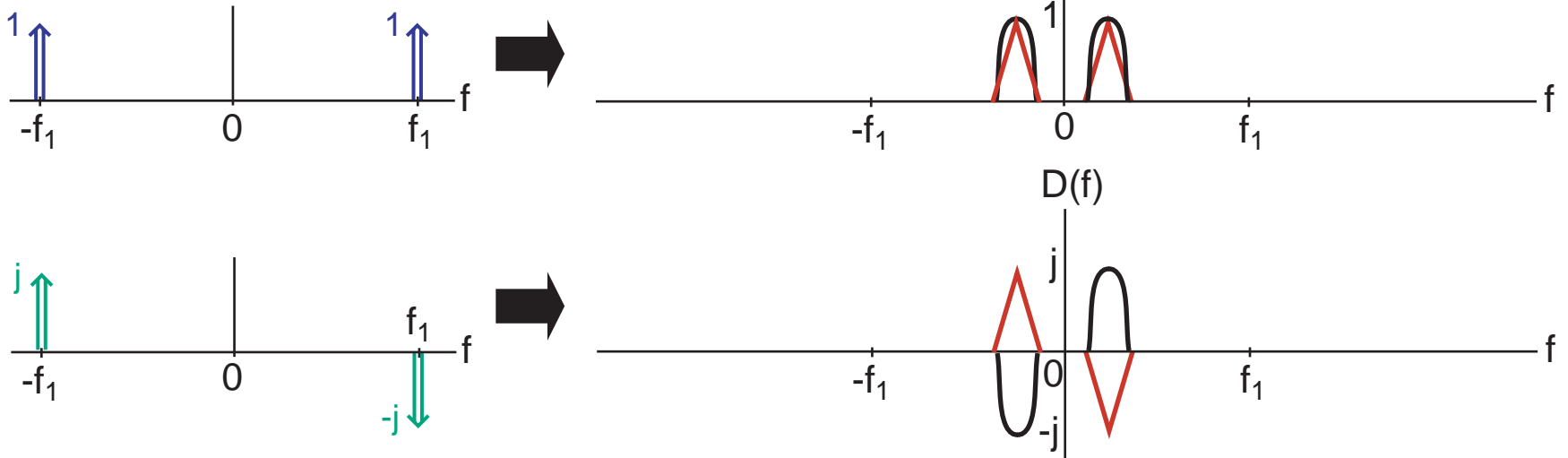
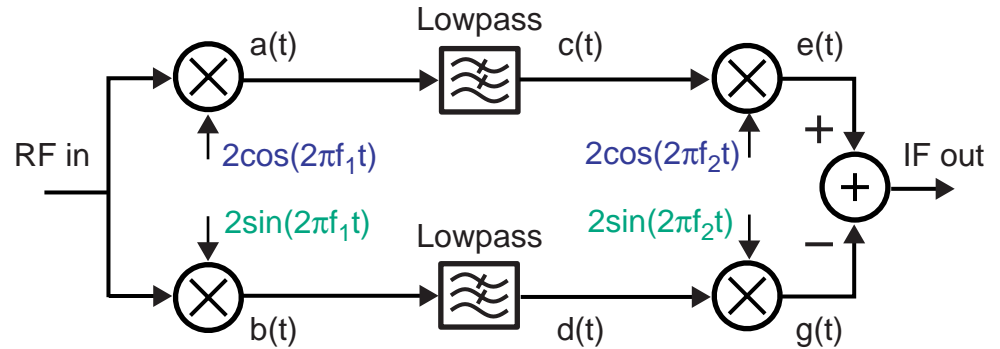
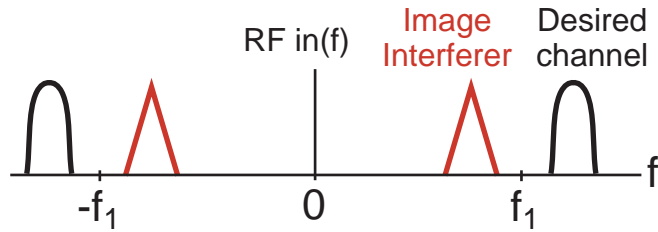

Image Reject Mixer Principles – Step 3

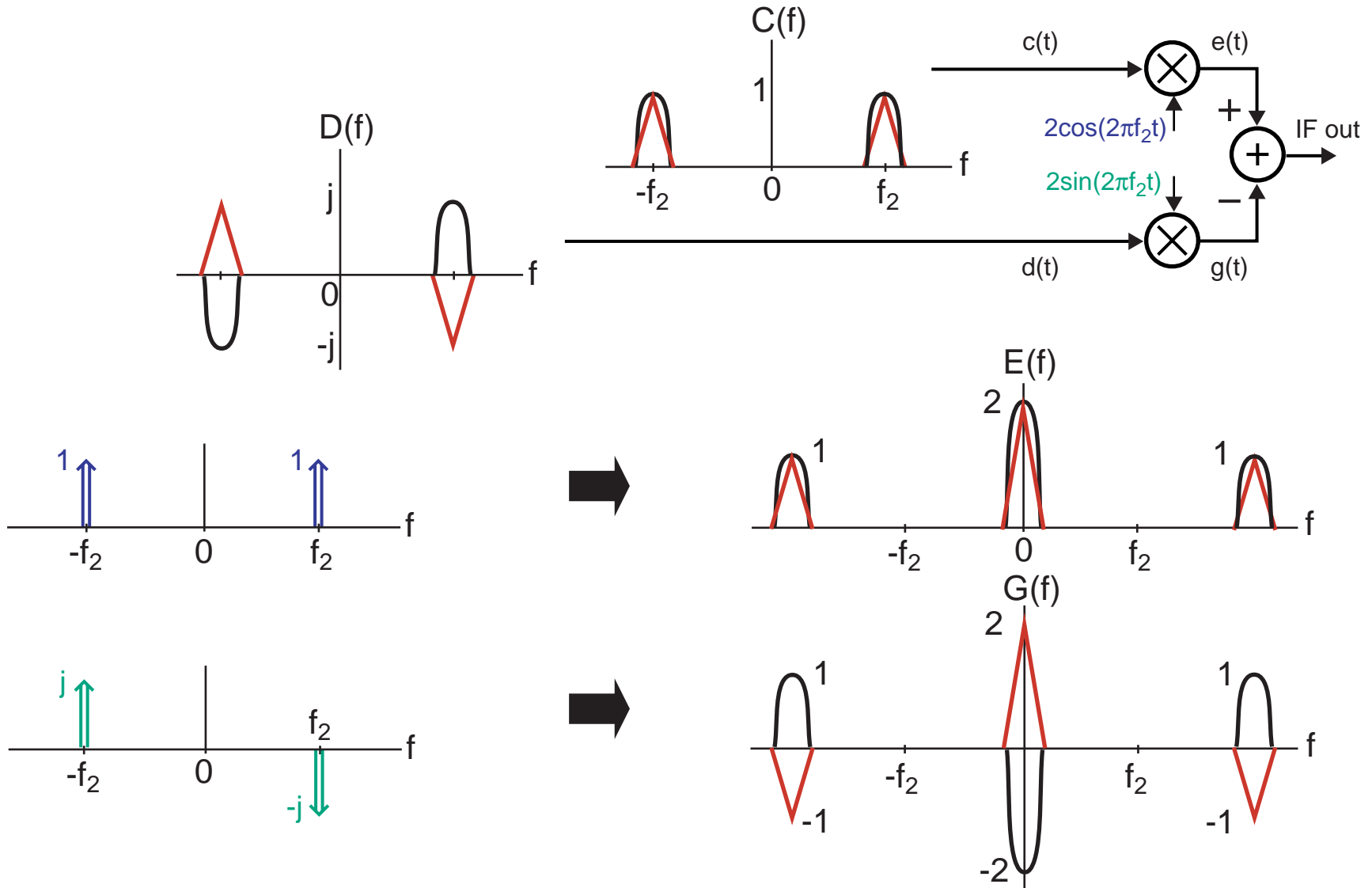

Image Reject Mixer Principles – Step 4

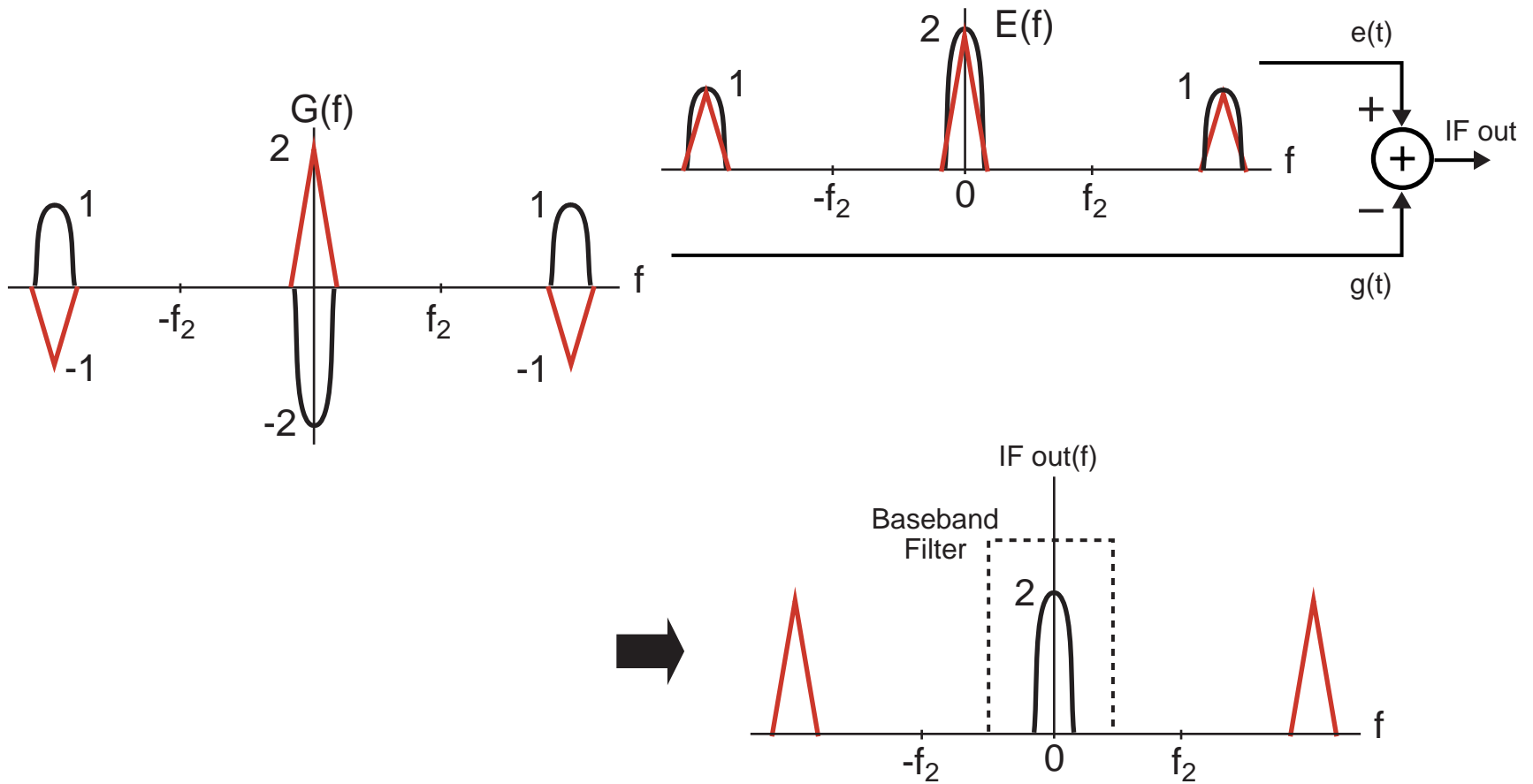
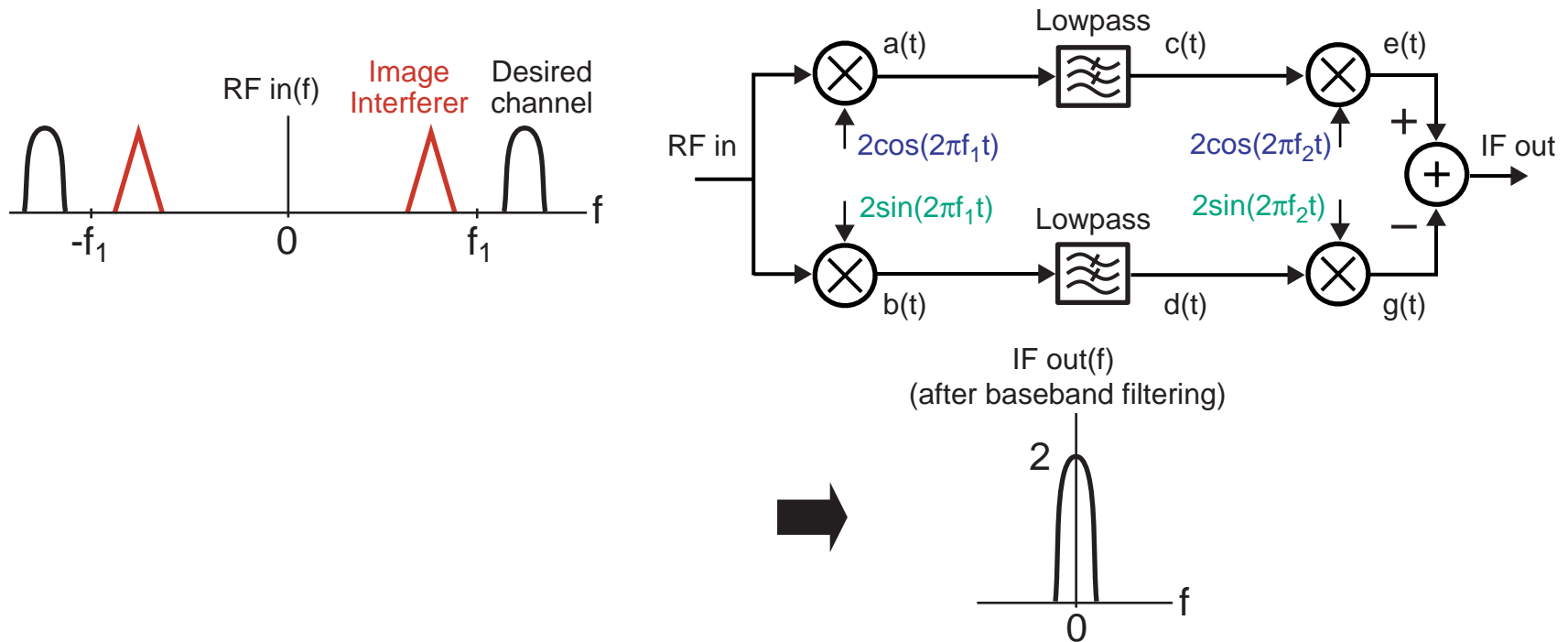
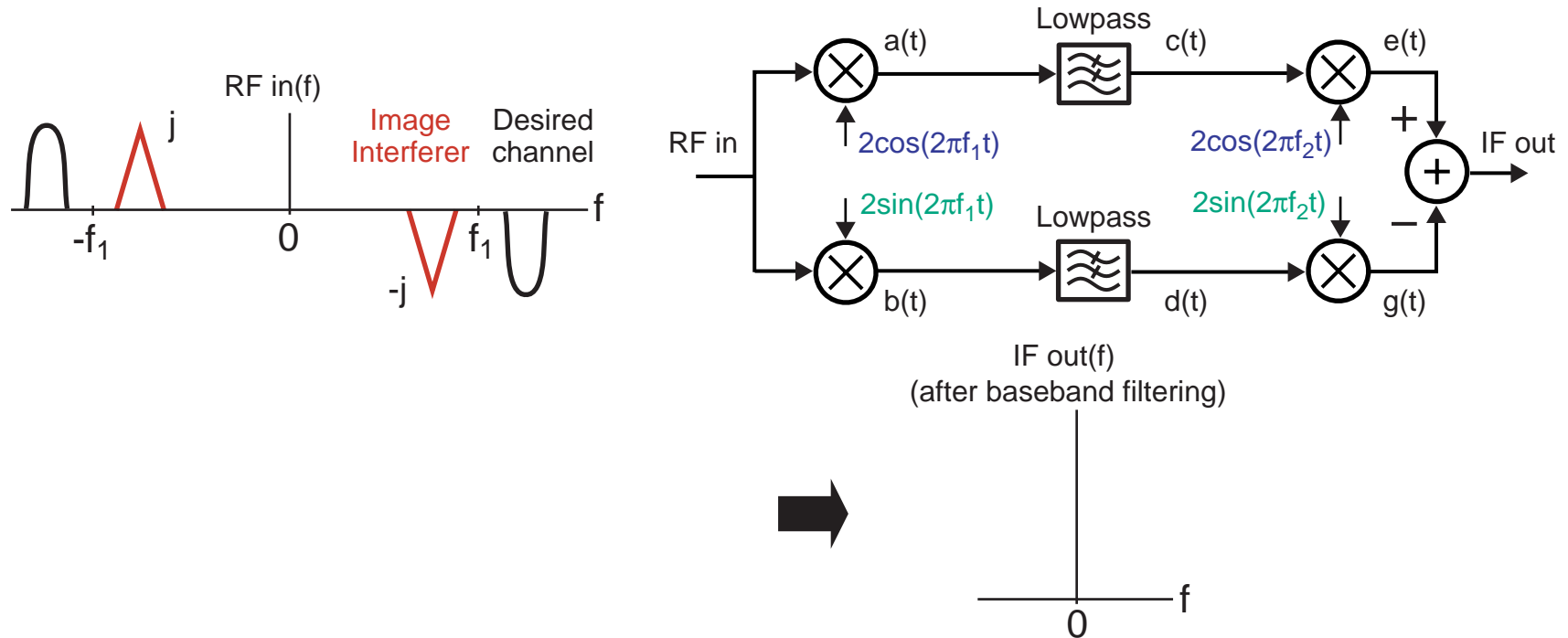

Image Reject Mixer Principles – Implementation Issues



- For all analog architecture, additional mixers introduce more mismatch and noise (limits image rejection and noise figure)
 - Can fix this problem by digitizing $c(t)$ and $d(t)$, and then performing final mixing in the digital domain
- Can generate accurate quadrature sine wave signals by using a frequency divider

What if $RF\ in(f)$ is Purely Imaginary?



- Both desired and image signals disappear!
 - Architecture is sensitive to the phase of the RF input
- Can we modify the architecture to fix this issue?

Modification of Mixer Architecture for Imaginary RF in(f)

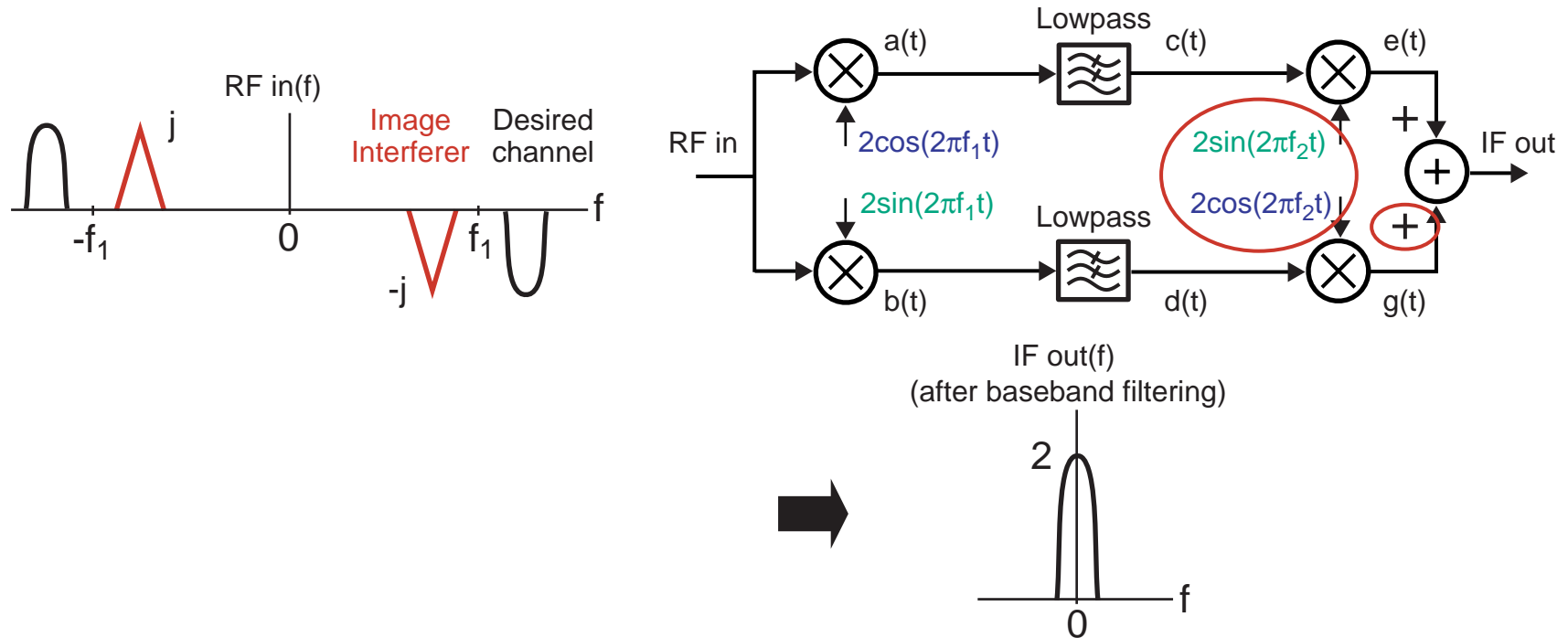

- **Desired channel now appears given two changes**
 - Sine and cosine demodulators are switched in second half of image rejection mixer
 - The two paths are now added rather than subtracted
- **Issue – architecture now zeros out desired channel when RF in(f) is purely real**

Overall Mixer Architecture – Use I/Q Demodulation

real part of RF in(f)

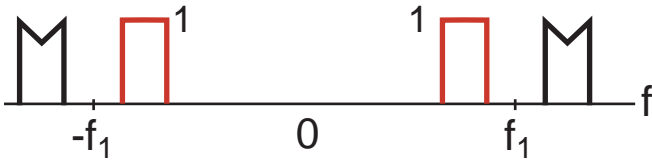

imag. part of RF in(f)

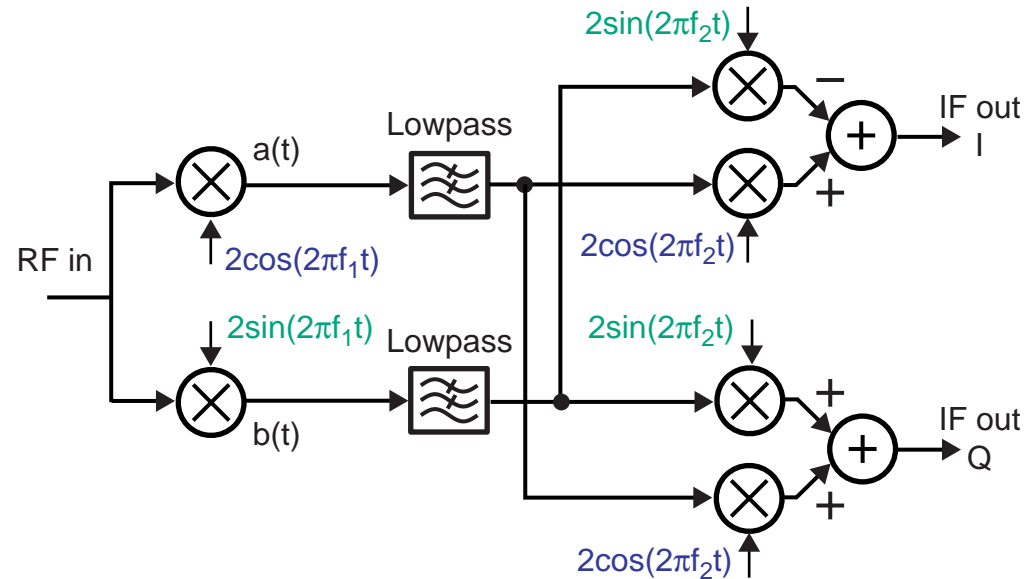
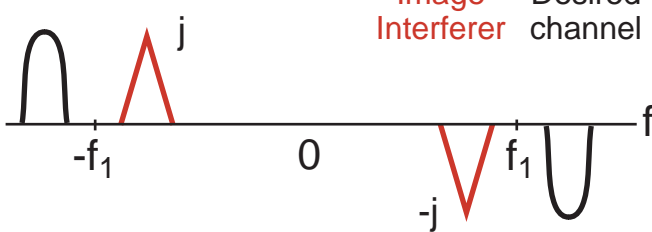

IF out(f) (I component)
(after baseband filtering)

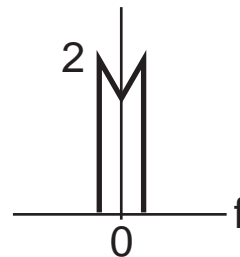

IF out(f) (Q component)
(after baseband filtering)

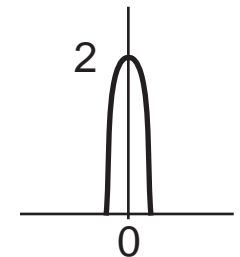

- Both real and imag. parts of RF input now pass through

Example of Double Conversion Image Reject Mixer

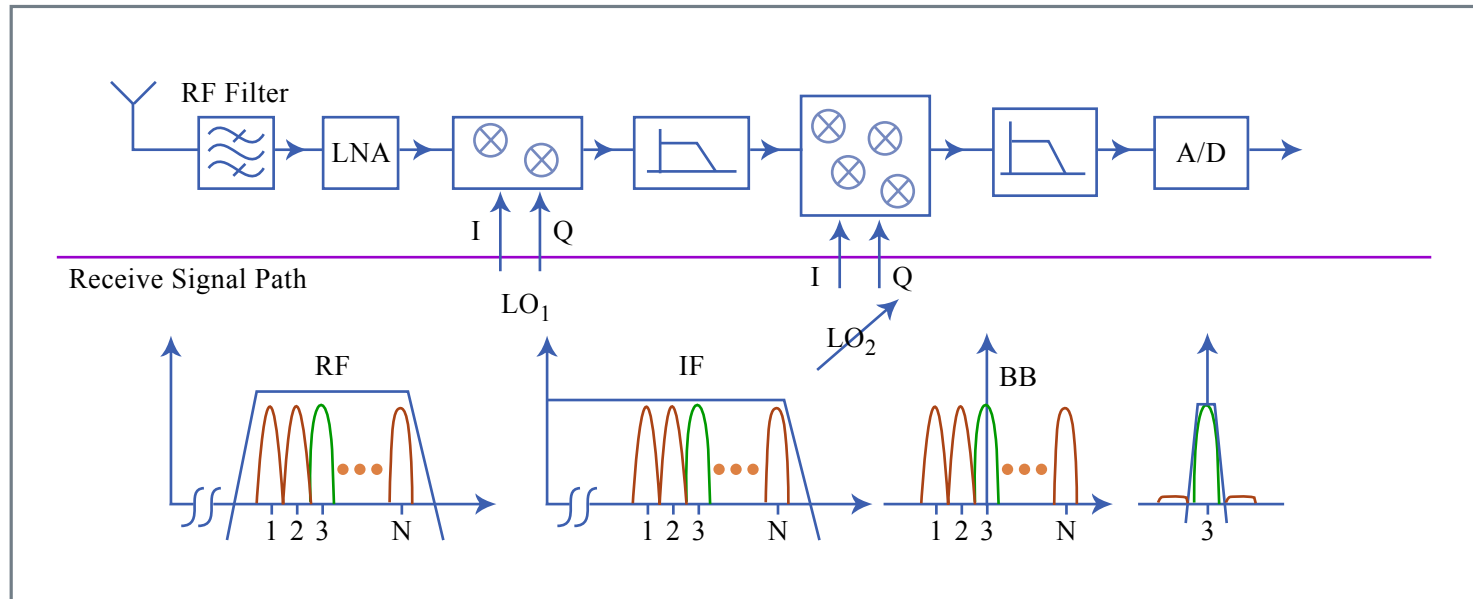
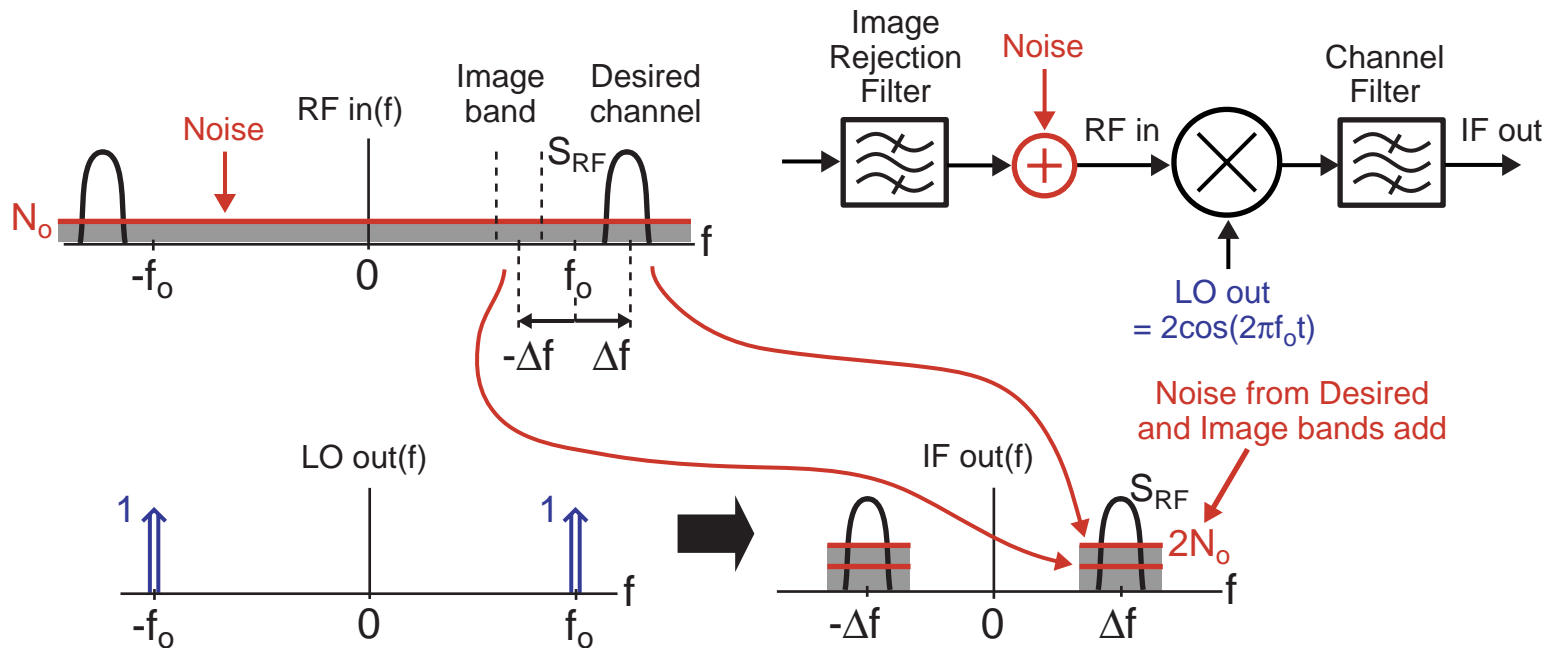

Figure by MIT OCW.

REF: "A 1.9-GHz Wide-Band IF Double Conversion CMOS Receiver for Cordless Telephone Applications," J. C. Rudell, et. al. IEEE J. Solid-State Circuits, Vol. SC-32, Dec. 1997 pp 2071-2088

- **I/Q Image rejection provided by 6 mixers**
- **IF filtering is LPF: single-chip integration is easier**
- **LO frequency is unequal to carrier – LO leakage is not an issue**

Mixer Single-Sideband (SSB) Noise Figure



- **Issue – broadband noise from mixer or front end filter will be present in both image and desired bands**
 - Noise from both image and desired bands will combine in desired channel at IF output
 - Neither image reject filter not channel filter can remove this
 - The SSB noise figure computes (correctly) noise in both the desired signal band and image band with signal only in the desired band (SSB signal, but DSB noise)

Mixer Double-Sideband (DSB) Noise Figure

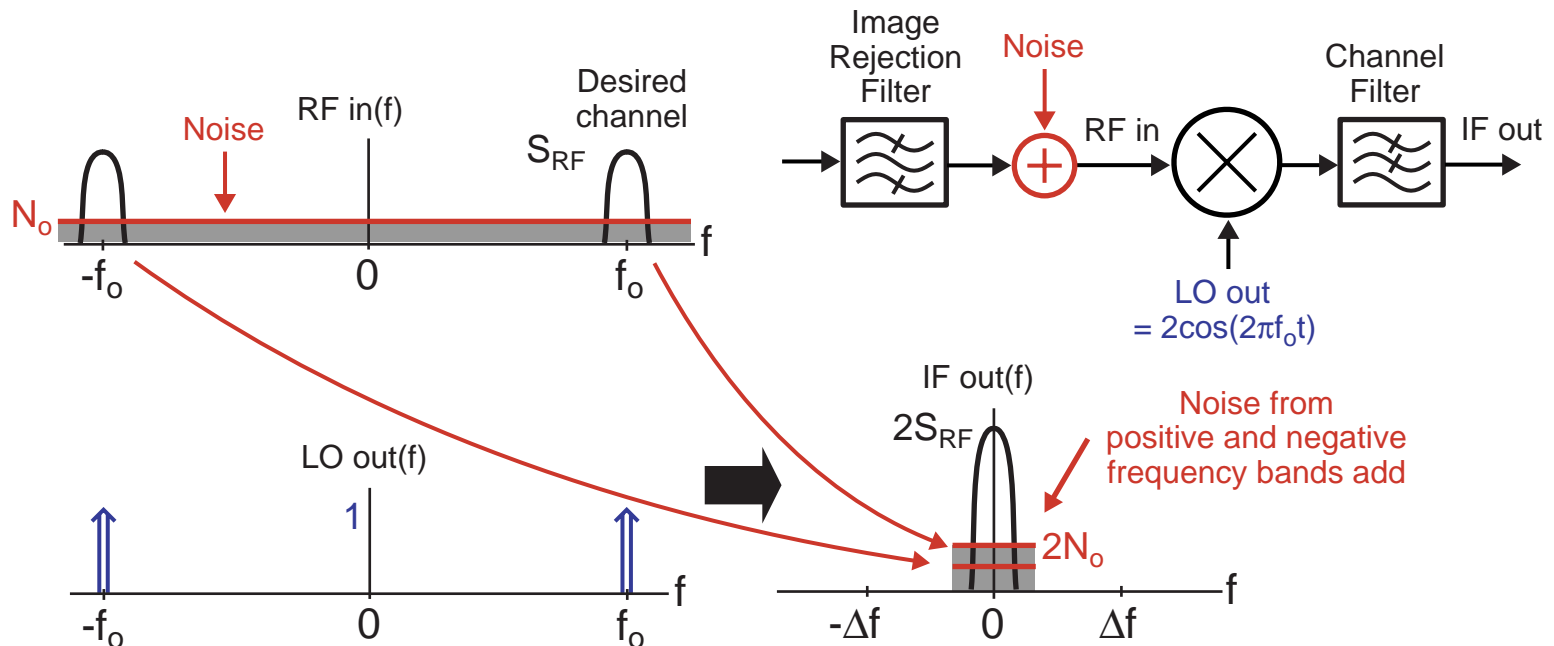

- DSB NF assumes signal and noise in both sidebands (thus 3dB lower noise figure) – this is misleading because there is no signal in the image band in heterodyne receivers
- For zero IF, there is no image band-DSB noise figure is appropriate
 - Noise from positive and negative frequencies combine, but the signals do as well
- DSB noise figure is 3 dB lower than SSB noise figure
 - DSB noise figure often quoted since it sounds better
- For either case, Noise Figure should be computed through simulation

A Practical Issue – Square Wave LO Oscillator Signals

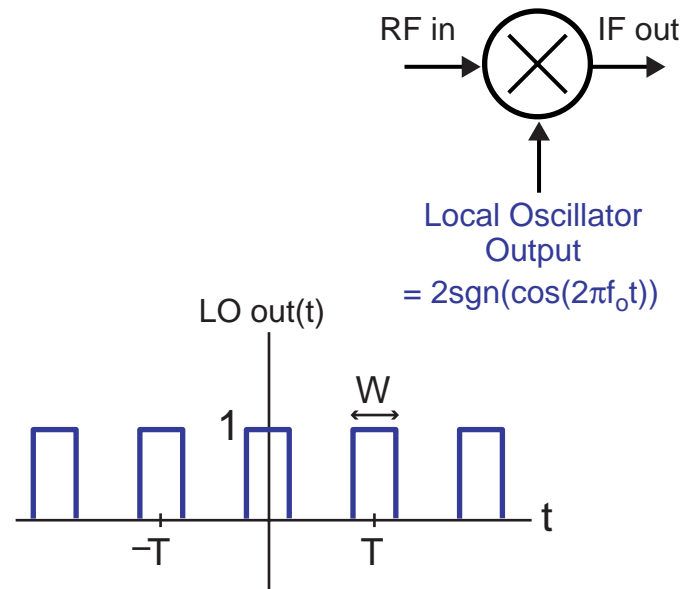

- **Square waves are easier to generate than sine waves**
 - How do they impact the mixing operation when used as the LO signal?
 - We will briefly review Fourier transforms (series) to understand this issue

Two Important Transform Pairs

- Transform of a rectangle pulse in time is a sinc function in frequency

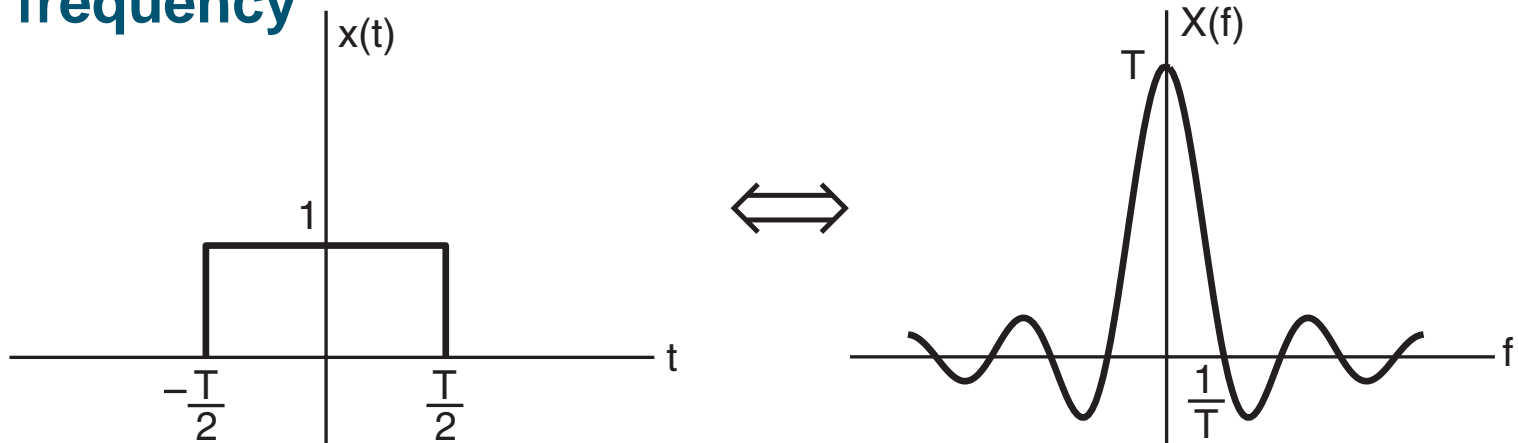

- Transform of an impulse train in time is an impulse train in frequency

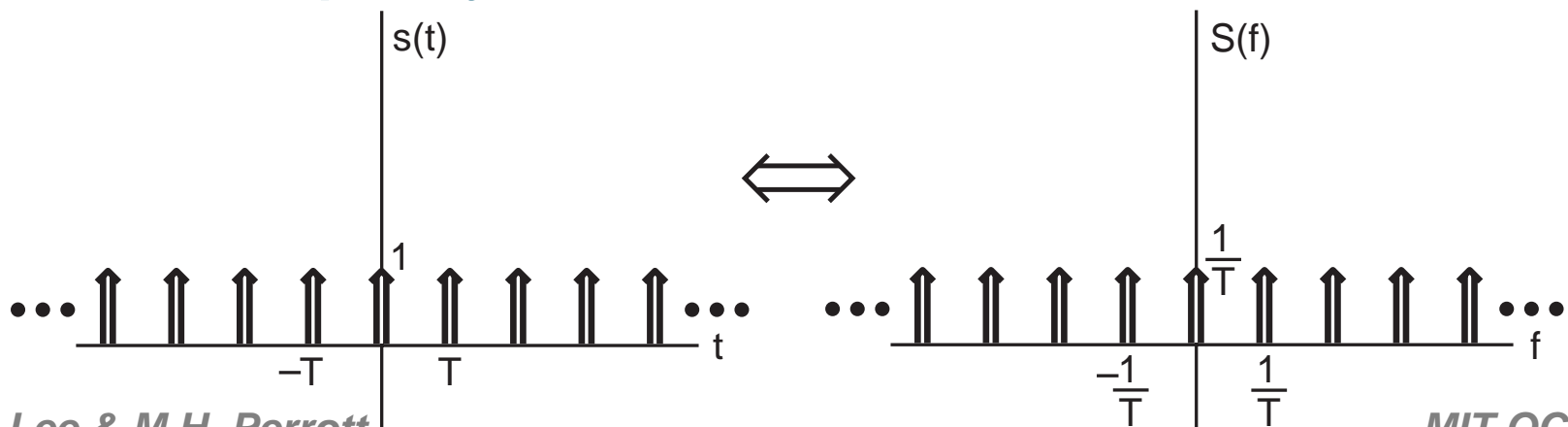

Decomposition of Square Wave to Simplify Analysis

- Consider now a square wave with duty cycle W/T

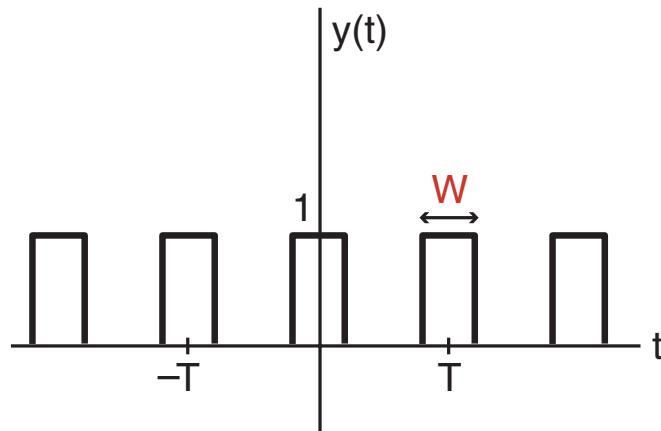

- Decomposition in time

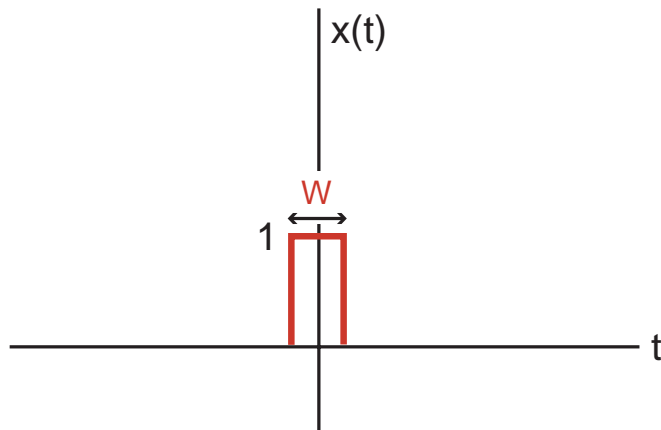

*

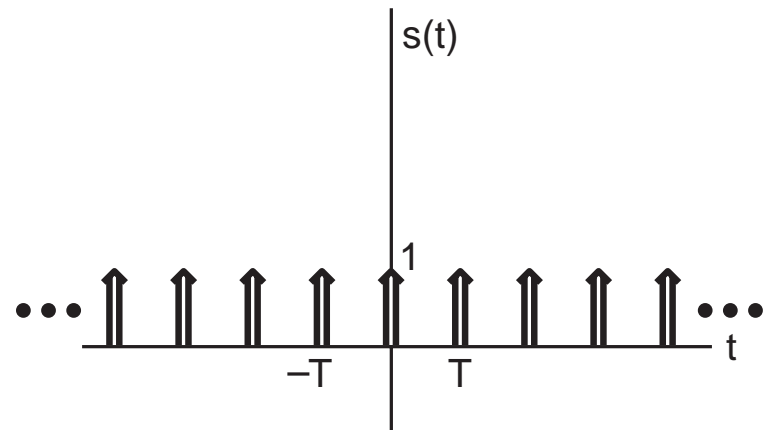

Associated Frequency Transforms

- Consider now a square wave with duty cycle W/T

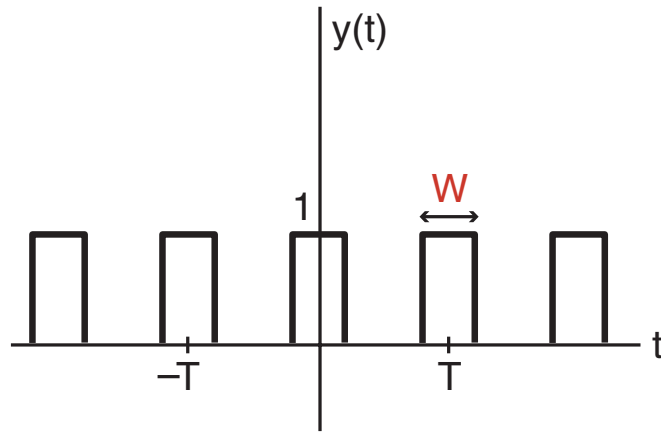

- Decomposition in frequency

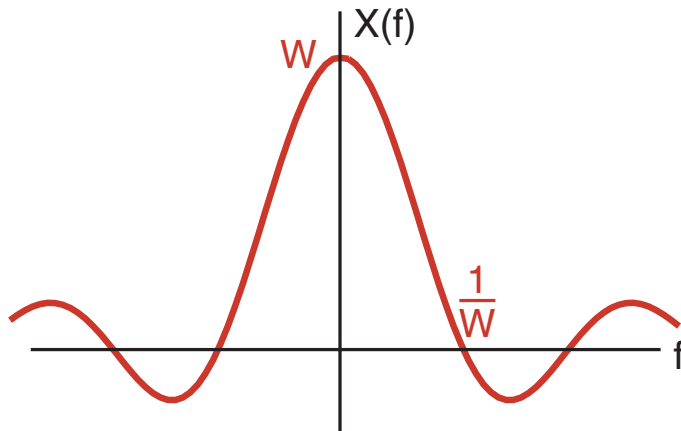

×

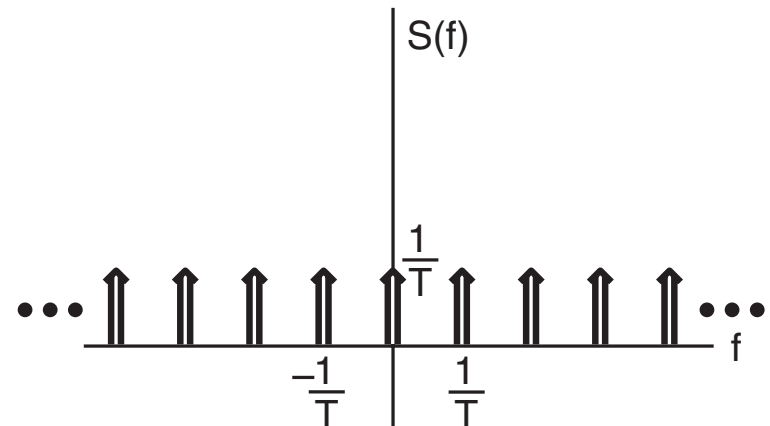

Overall Frequency Transform of a Square Wave

- **Resulting transform relationship**

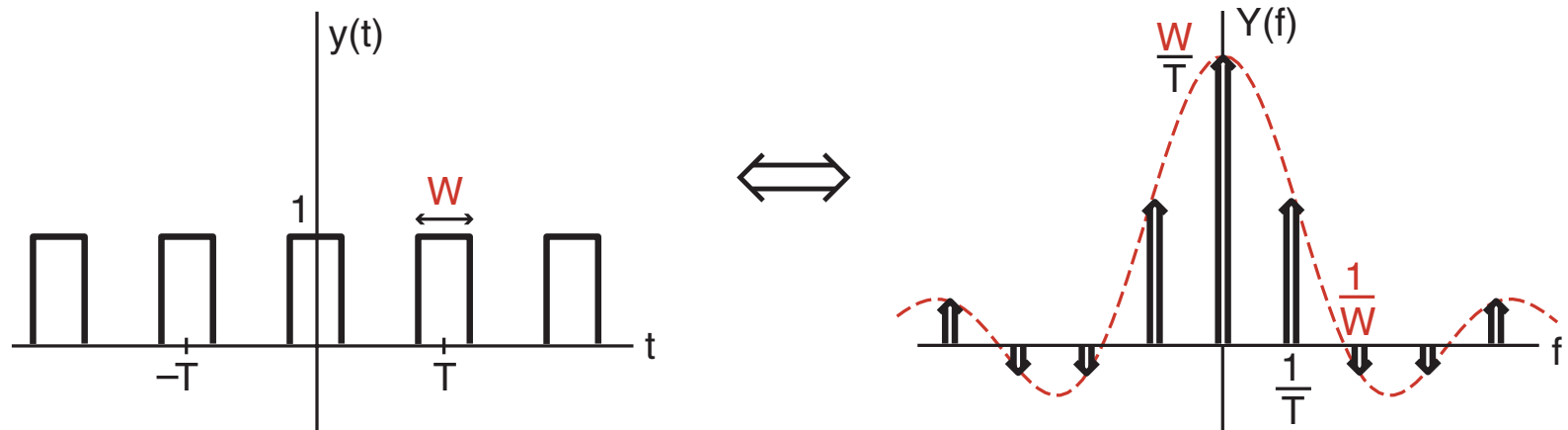

- **Fundamental at frequency $1/T$**
 - Higher harmonics have lower magnitude
- **If $W = T/2$ (i.e., 50% duty cycle)**
 - No even harmonics!
- **If the waveform is between $1/2$ and $-1/2$ (rather than 1 and 0)**
 - No DC component (50% duty cycle)

Analysis of Using Square-Wave for LO Signal

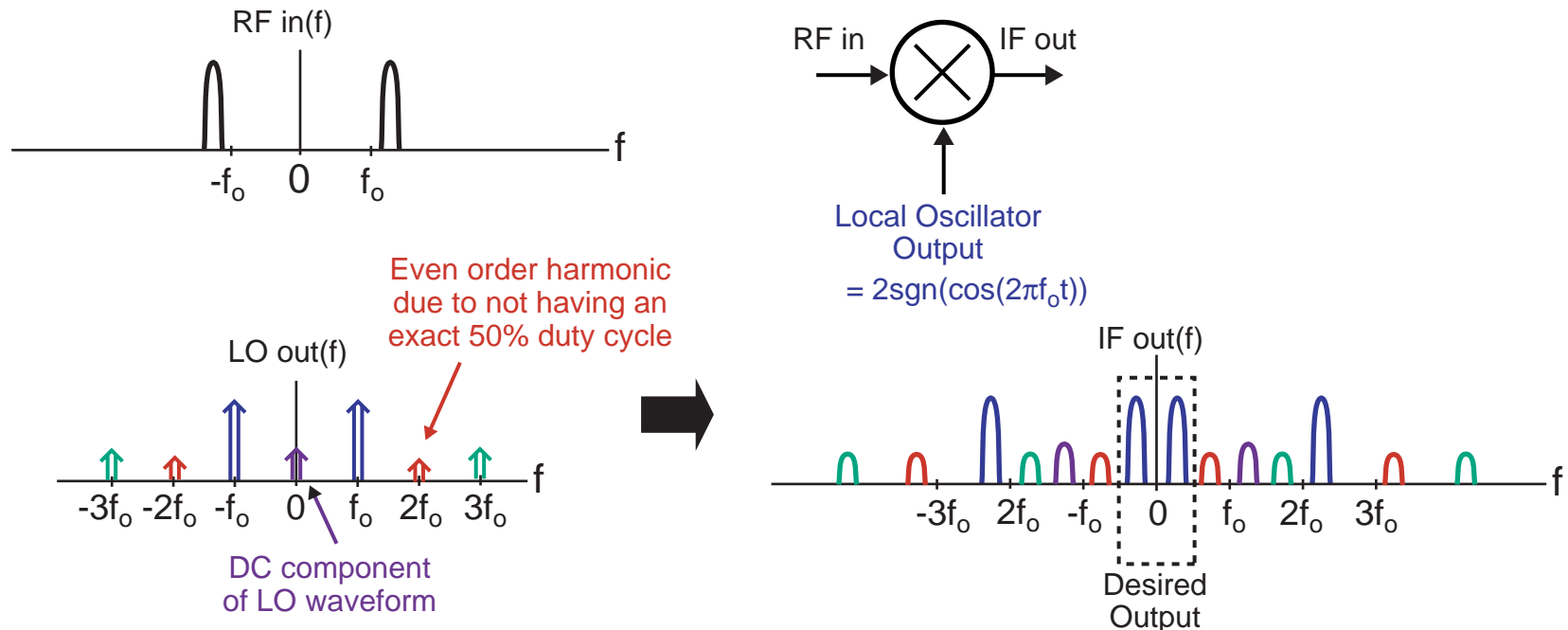

- Each frequency component of LO signal will now mix with the RF input
 - If RF input spectrum sufficiently narrowband with respect to f_0 , then no aliasing will occur
- Desired output (mixed by the fundamental component) can be extracted using a filter at the IF output

Voltage Conversion Gain

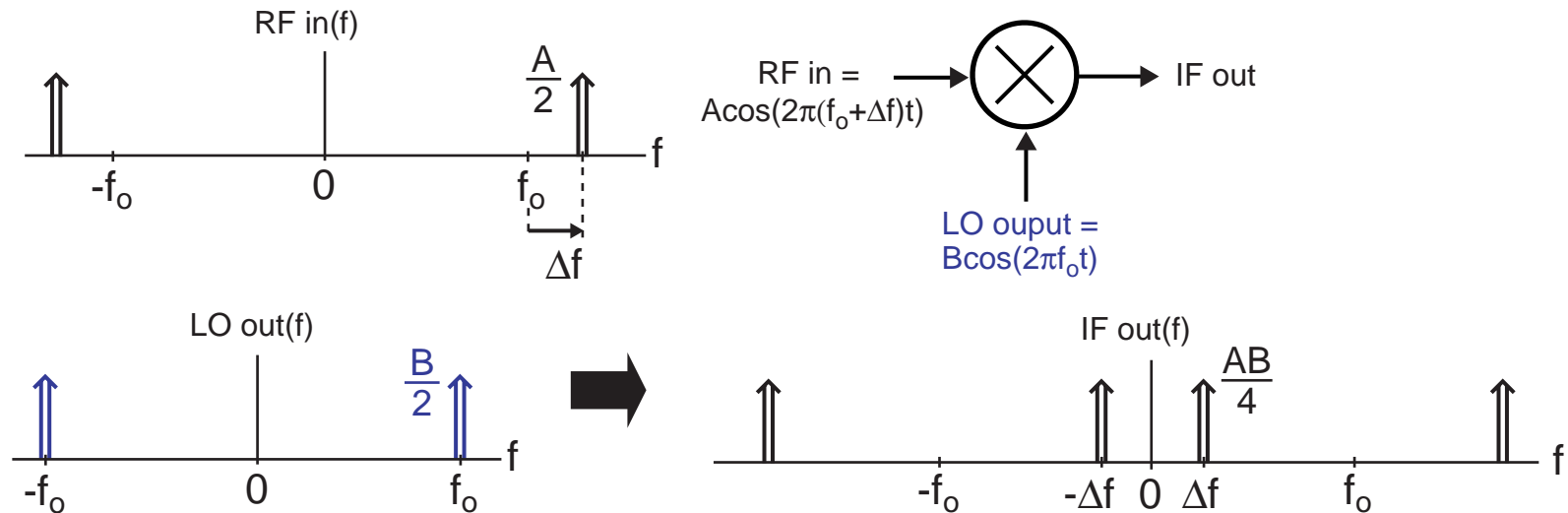

- Defined as voltage ratio of desired IF value to RF input
- Example: for an ideal mixer with RF input = $A \sin(2\pi(f_o + \Delta f)t)$ and sine wave LO signal = $B \cos(2\pi f_o t)$

$$IF \text{ out}(t) = \frac{AB}{2} \left(\cos(2\pi(\Delta f)t) + \cos(2\pi(2f_o + \Delta f)t) \right)$$

$$\Rightarrow \text{Voltage Conversion Gain} = \frac{AB/2}{A} = \frac{B}{2}$$

- For practical mixers, value depends on mixer topology and LO signal (i.e., sine or square wave)

Impact of High Voltage Conversion Gain

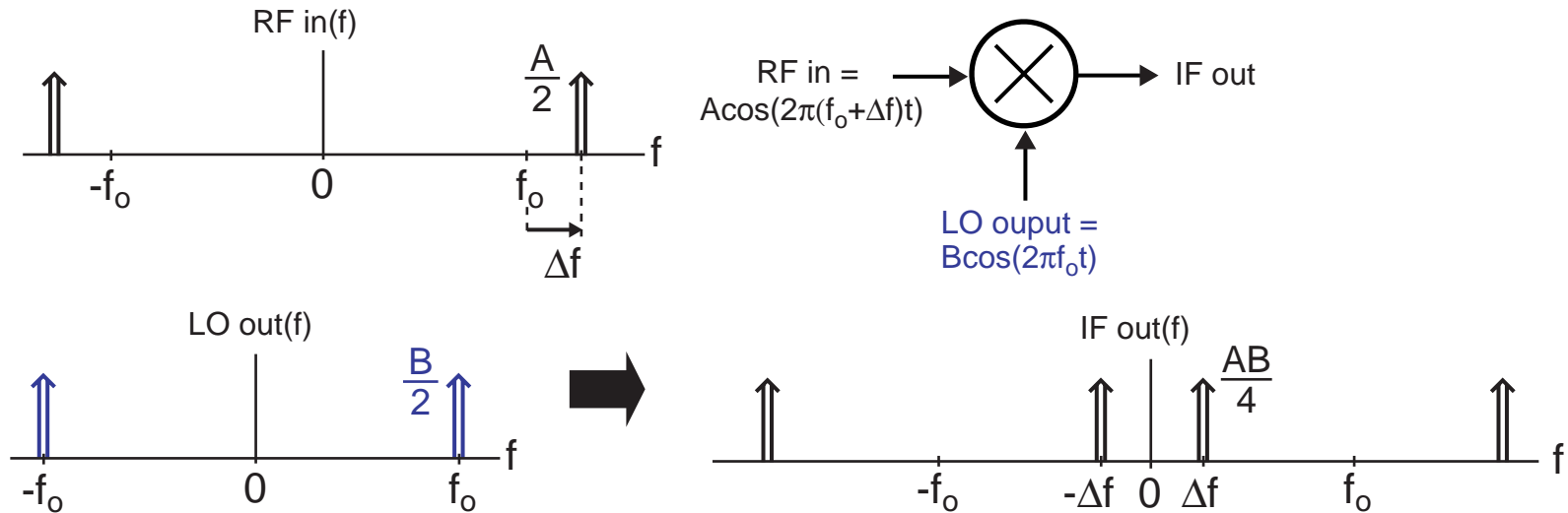

- **Benefit of high voltage gain**
 - The noise of later stages will have less of an impact
- **Issues with high voltage gain**
 - May be accompanied by higher noise figure than could be achieved with lower voltage gain
 - May be accompanied by nonlinearities that limit interference rejection (i.e., passive mixers can generally be made more linear than active ones)

Impact of Nonlinearity in Mixers

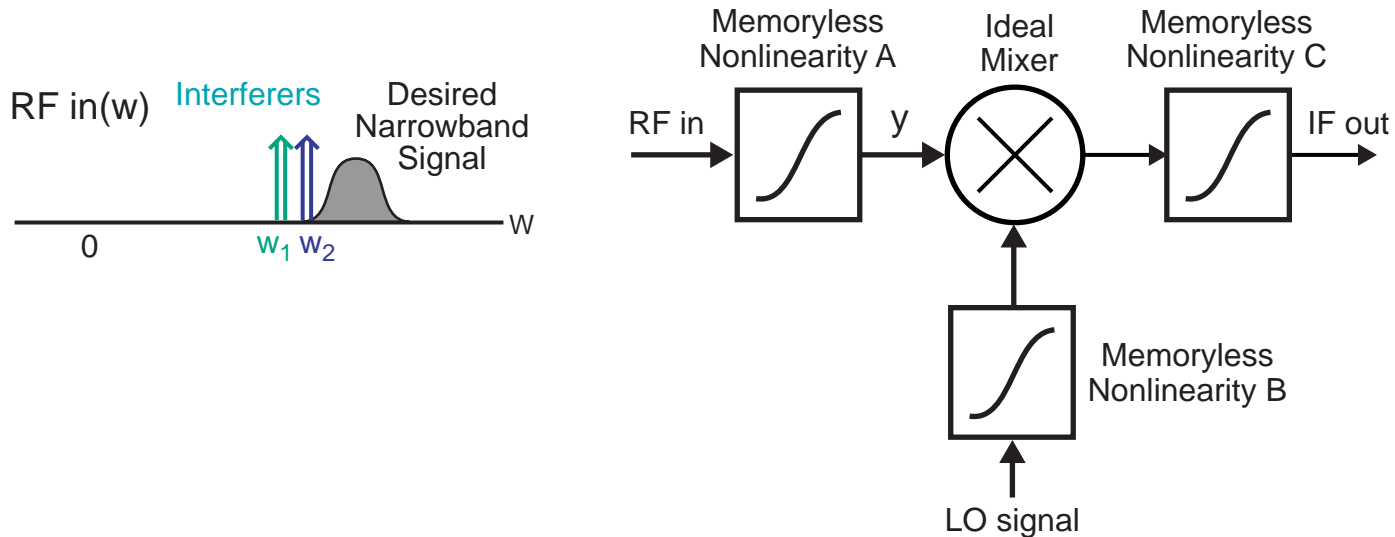

- Ignoring dynamic effects, we can model mixer as nonlinearities around an ideal mixer
 - Nonlinearity A will have the same impact as LNA nonlinearity (measured with IIP3)
 - Nonlinearity B will change the spectrum of the LO signal
 - We already looked at an extreme case (square wave)
 - Changes conversion gain somewhat
 - Nonlinearity C will cause self mixing of IF output

Primary Focus is Typically Nonlinearity in RF Input Path

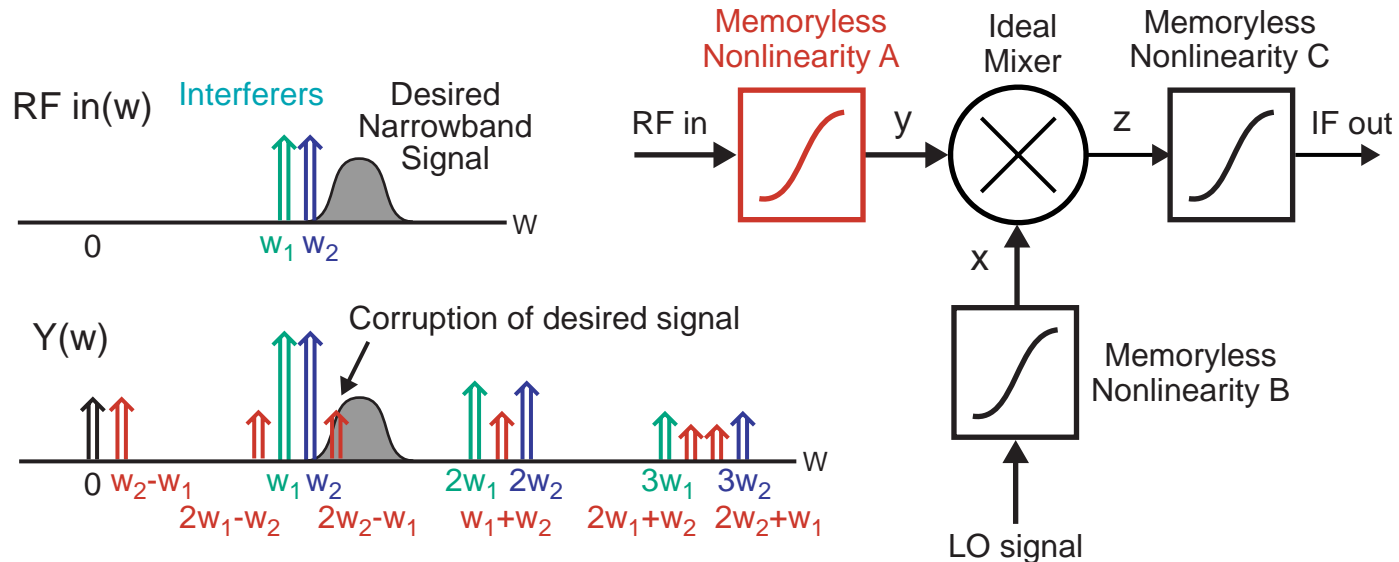

- **Nonlinearity B not detrimental in most cases**
 - LO signal often a square wave anyway
- **Nonlinearity C can be avoided by using a linear load (such as a resistor)**
- **Nonlinearity A can hamper rejection of interferers**
 - Characterize with IIP3 as with LNA designs
 - Use two-tone test to measure (similar to LNA)

The Issue of Balance in Mixers

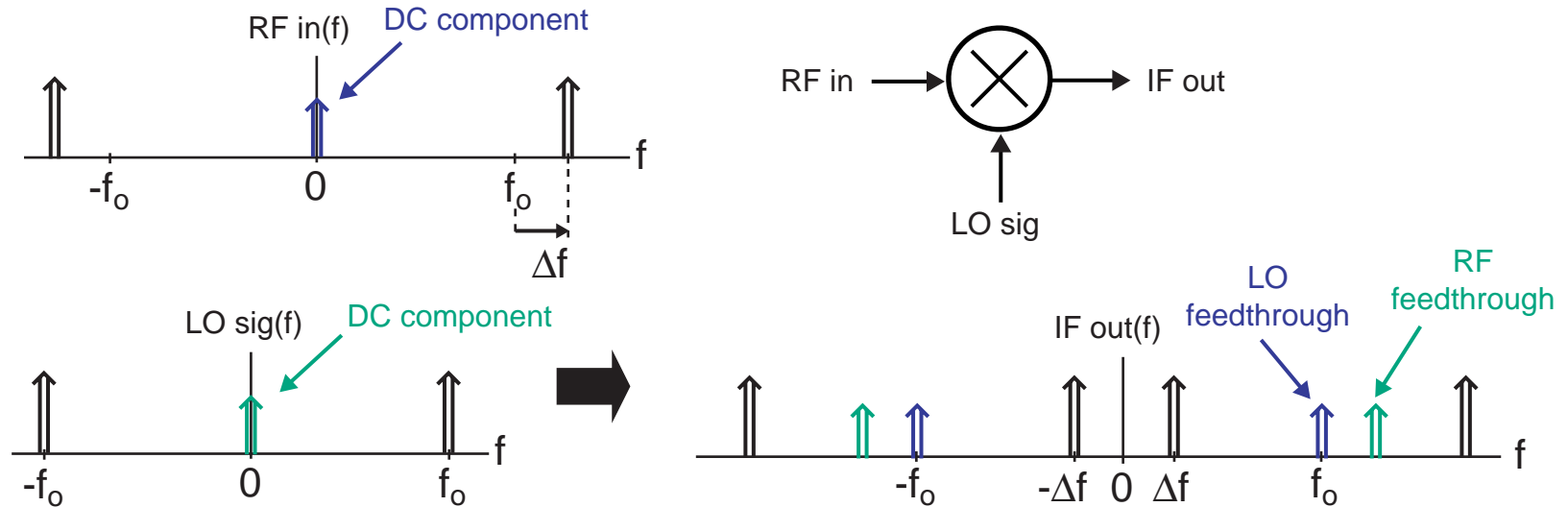

- A balanced signal is defined to have a zero DC component
- Mixers have two signals of concern with respect to this issue – LO and RF signals
 - Unbalanced RF input causes LO feedthrough
 - Unbalanced LO signal causes RF feedthrough
- Issue – transistors require a DC offset (e.g. V_T) for biasing

Achieving a Balanced LO Signal with DC Biasing

- Combine two mixer paths with LO signal 180 degrees out of phase between the paths

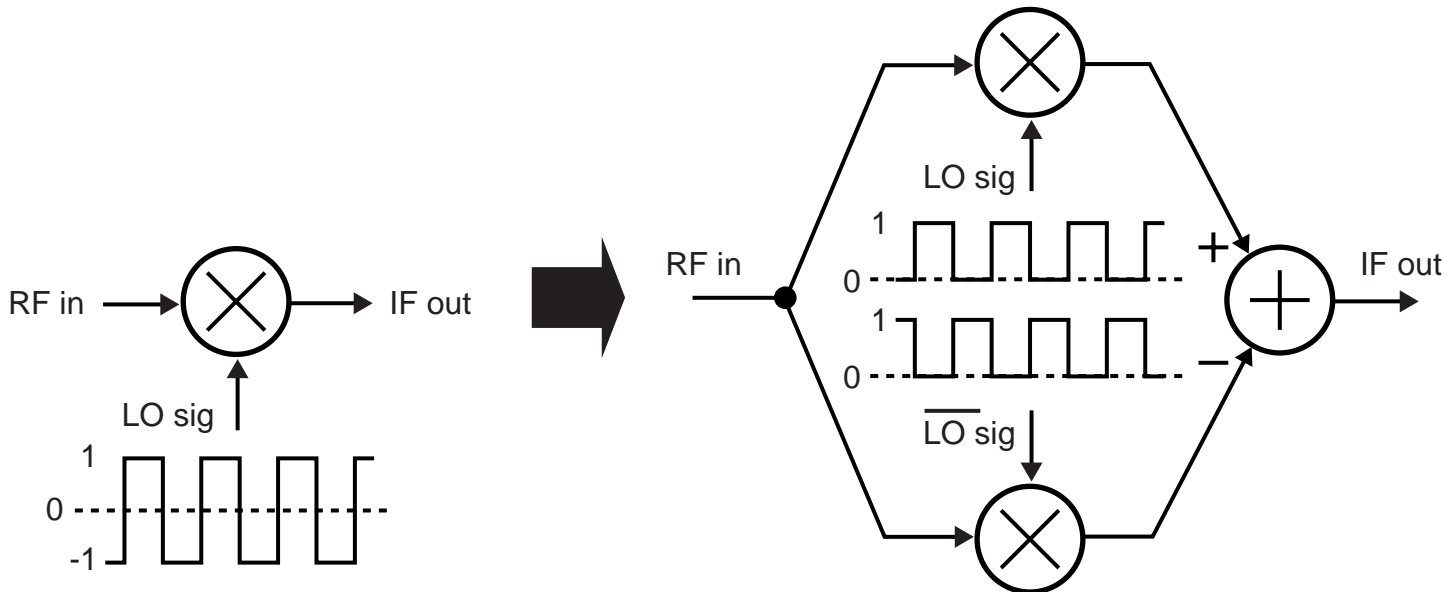

- DC component is cancelled

Single-Balanced Mixer

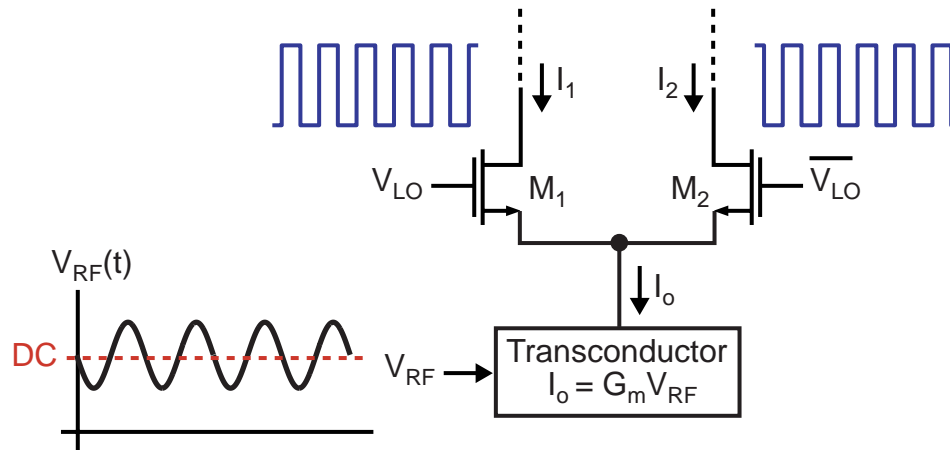

- Works by converting RF input voltage to a current, then switching current between each side of differential pair
- Achieves LO balance using technique on previous slide
 - Subtraction between paths is inherent to differential output
- LO swing should be no larger than needed to fully turn on and off differential pair
 - Square wave is best to minimize noise from M_1 and M_2
- Transconductor designed for high linearity

Transconductor Implementation 1

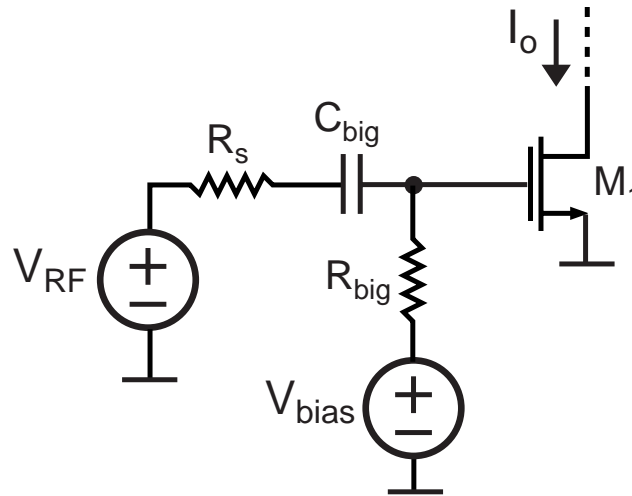

- Apply RF signal to input of common source amp
 - Transistor assumed to be in saturation
 - Transconductance value is the same as that of the transistor
- High V_{bias} places device in velocity saturation
 - Allows high linearity to be achieved

Transconductor Implementation 2

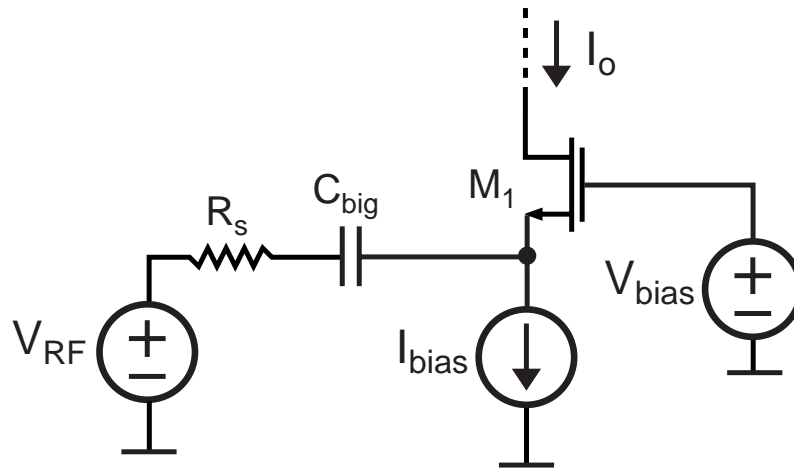

- Apply RF signal to a common gate amplifier
- Transconductance value set by inverse of series combination of R_s and $1/g_m$ of transistor
 - Amplifier is effectively degenerated to achieve higher linearity
- I_{bias} can be set for large current density through device to achieve higher linearity (velocity saturation)

Transconductor Implementation 3

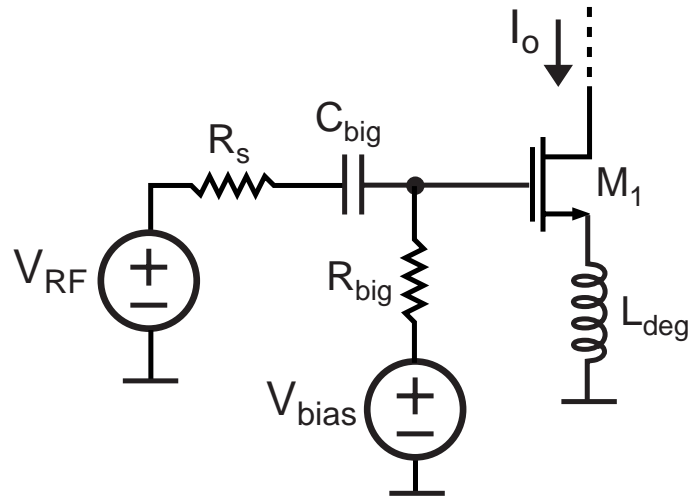

- **Add degeneration to common source amplifier**
 - **Inductor better than resistor**
 - No DC voltage drop
 - Increased impedance at high frequencies helps filter out undesired high frequency components
 - **Don't generally resonate inductor with C_{gs}**
 - Power match usually not required for IC implementation due to proximity of LNA and mixer

LO Feedthrough in Single-Balanced Mixers

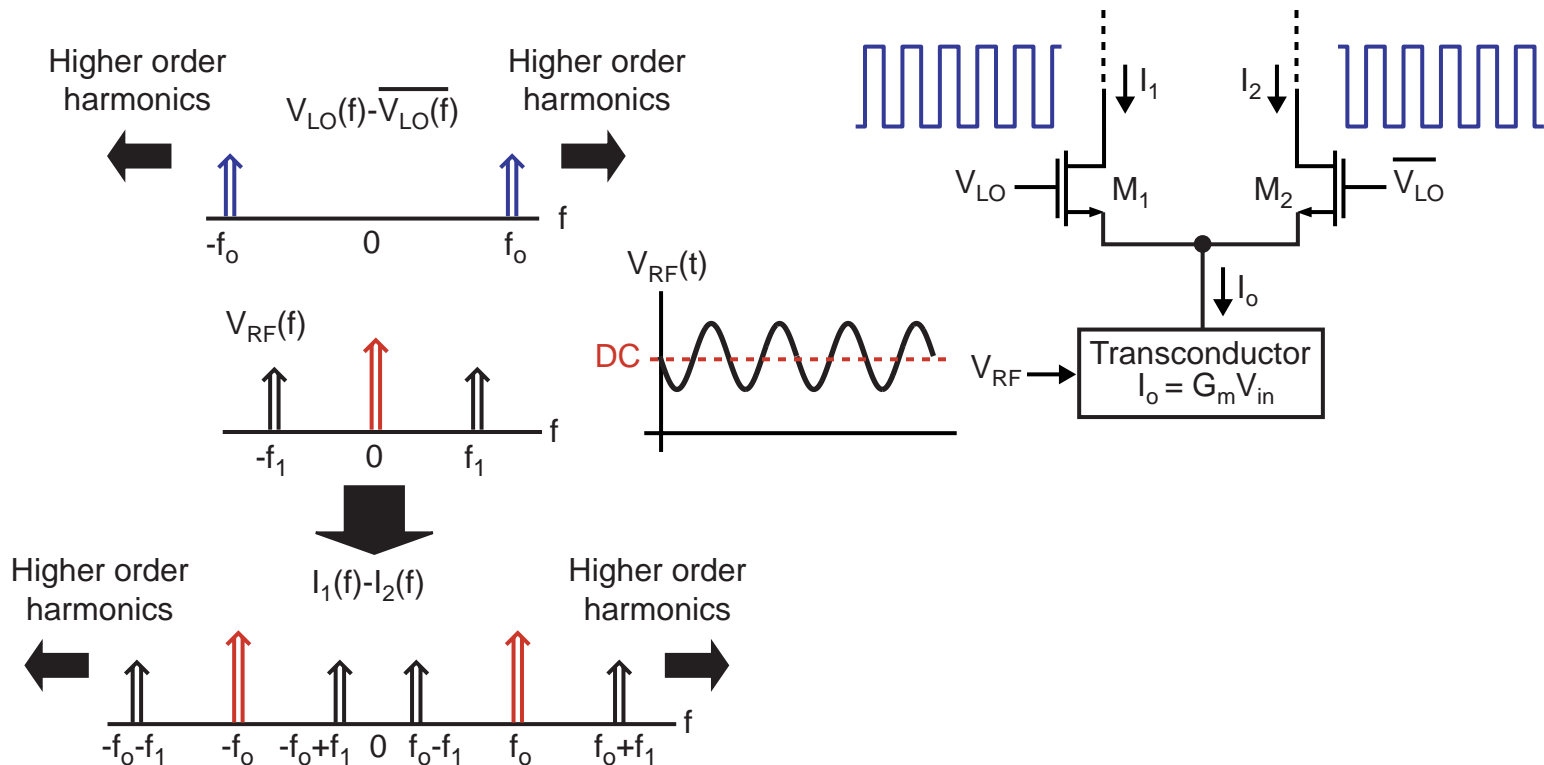

- **DC component of RF input causes very large LO feedthrough**
 - Can be removed by filtering, but can also be removed by achieving a zero DC value for RF input

Double-Balanced Mixer

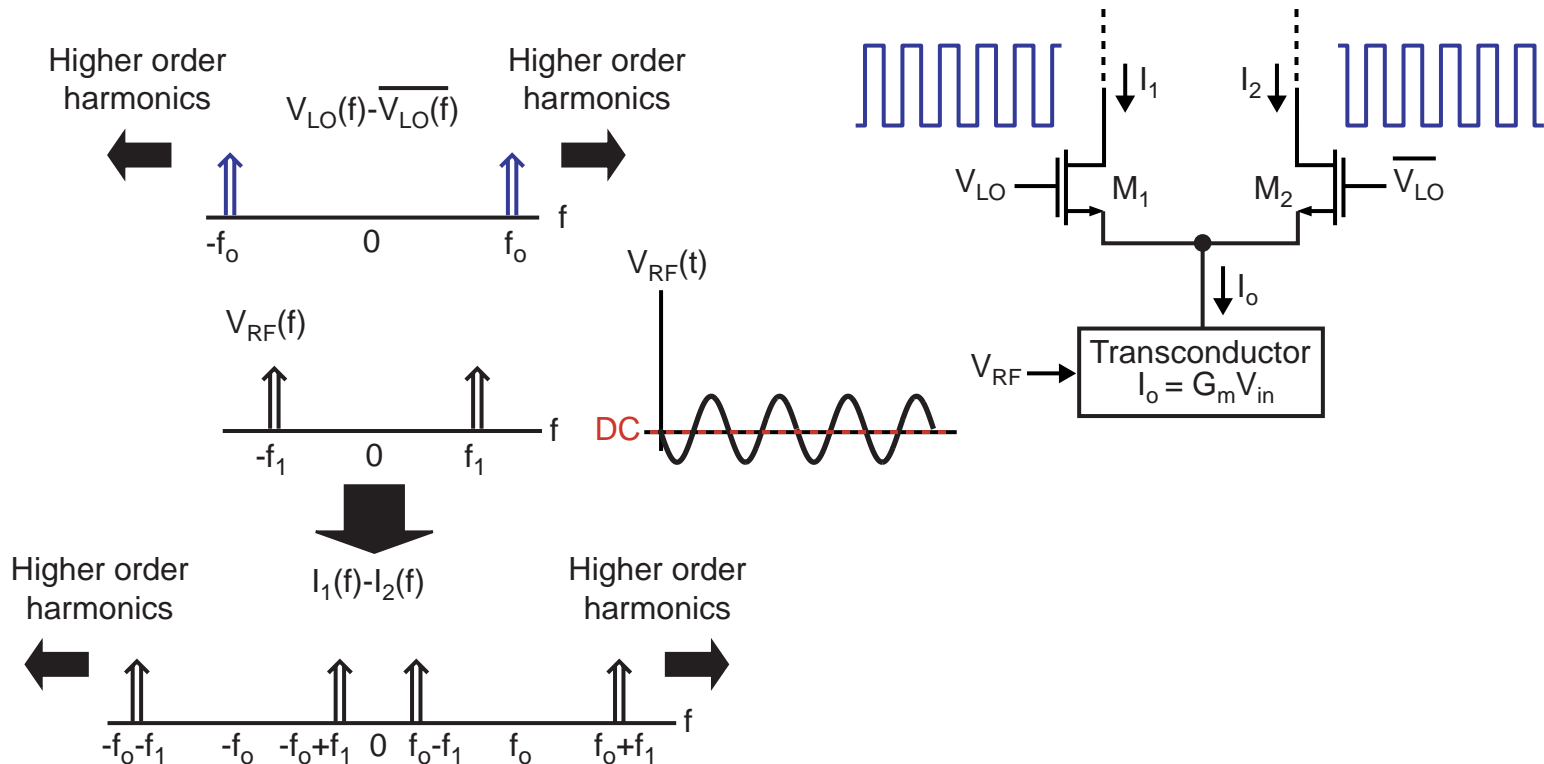

- DC values of LO and RF signals are zero (balanced)
- LO feedthrough dramatically reduced!
- But, practical transconductor needs bias current

Achieving a Balanced RF Signal with Biasing

- Use the same trick as with LO balancing

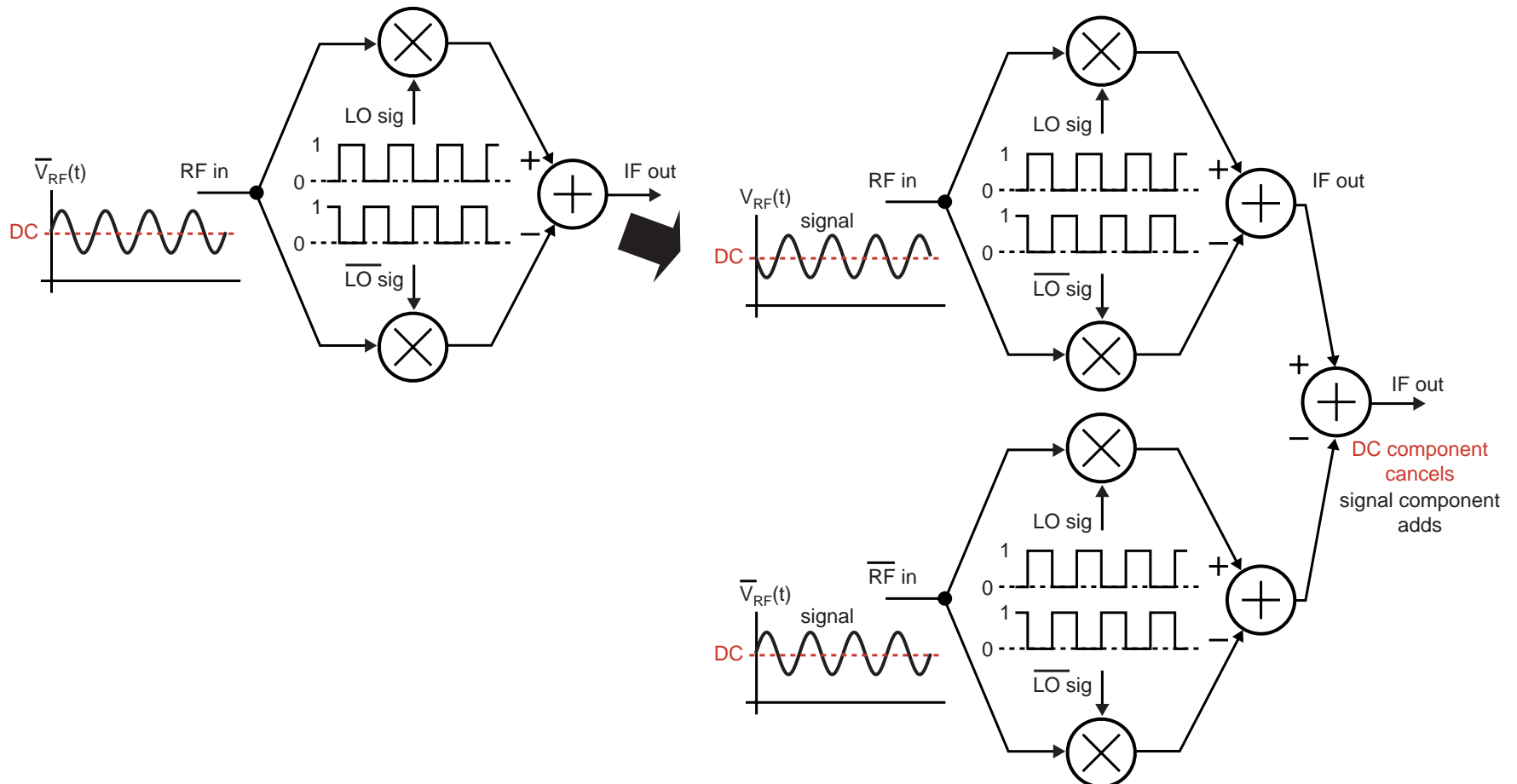

Double-Balanced Mixer Implementation

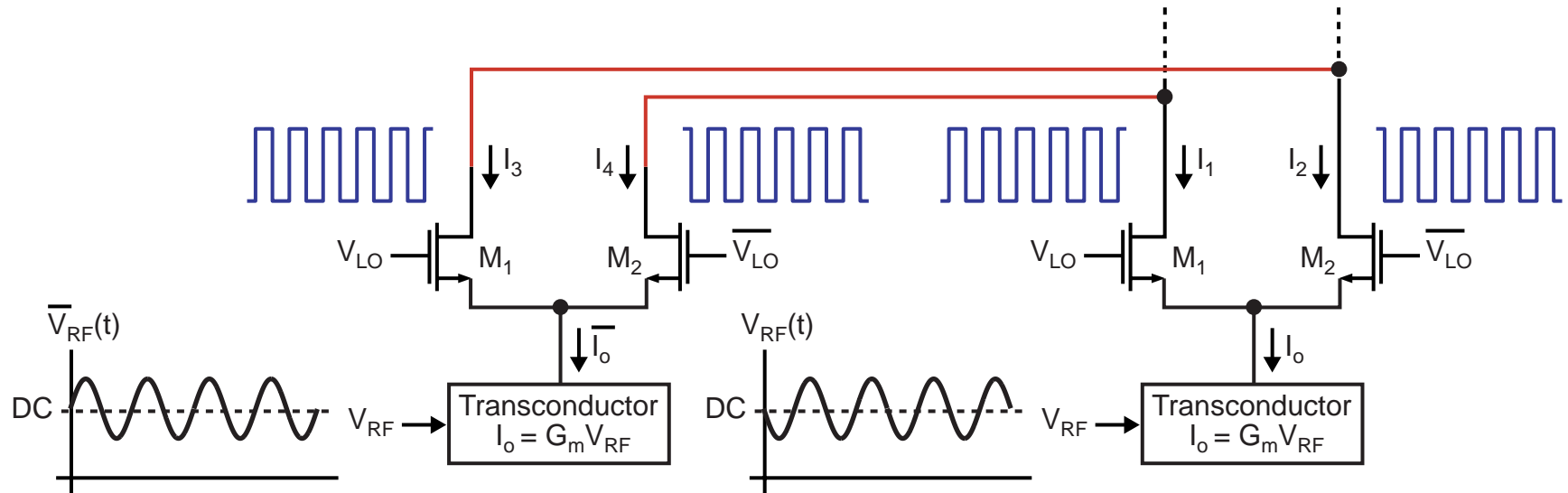

- Applies technique from previous slide
 - Subtraction at the output achieved by cross-coupling the output current of each stage

Gilbert Mixer

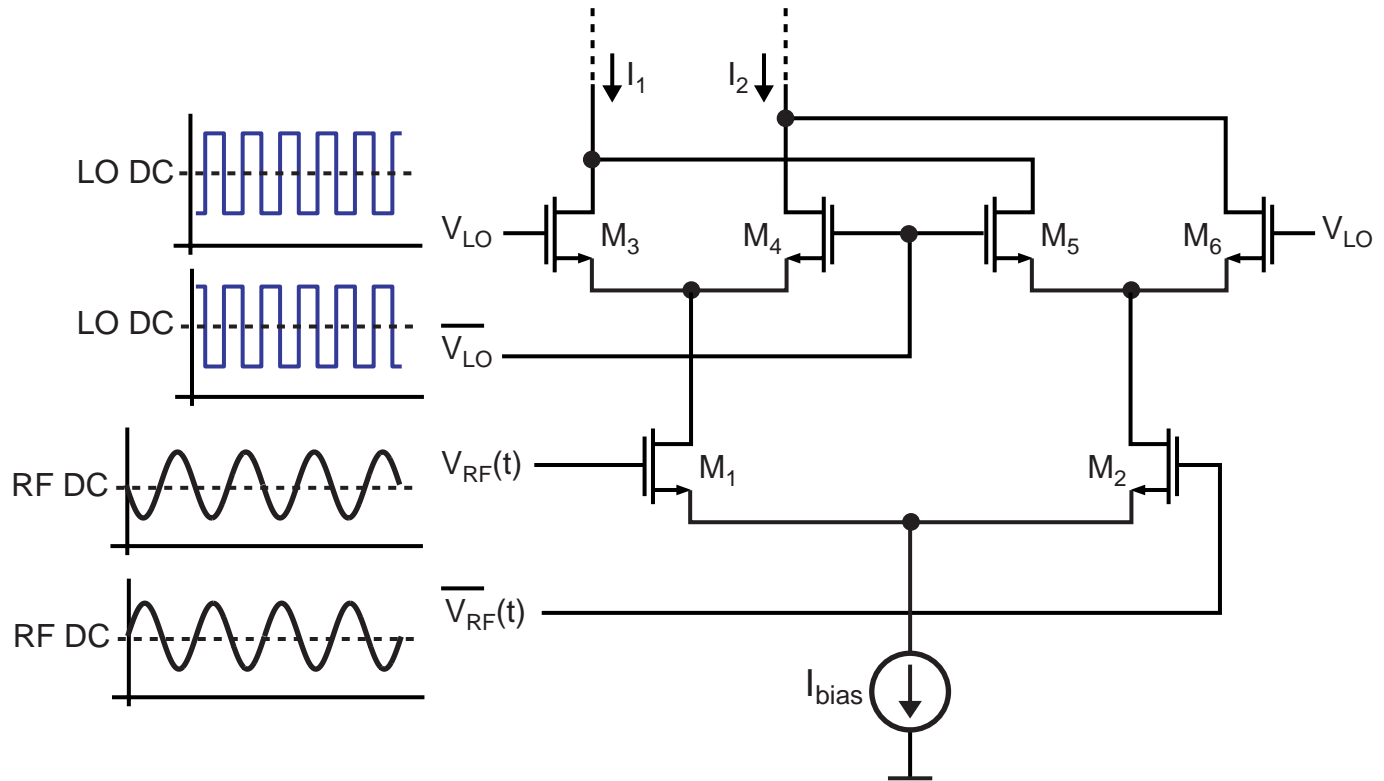

- Use a differential pair to achieve the transconductor implementation
- LO signal can be sinusoidal or square wave (preferred)
- This is the preferred mixer implementation for most radio systems!

A Highly Linear CMOS Analog Multiplier

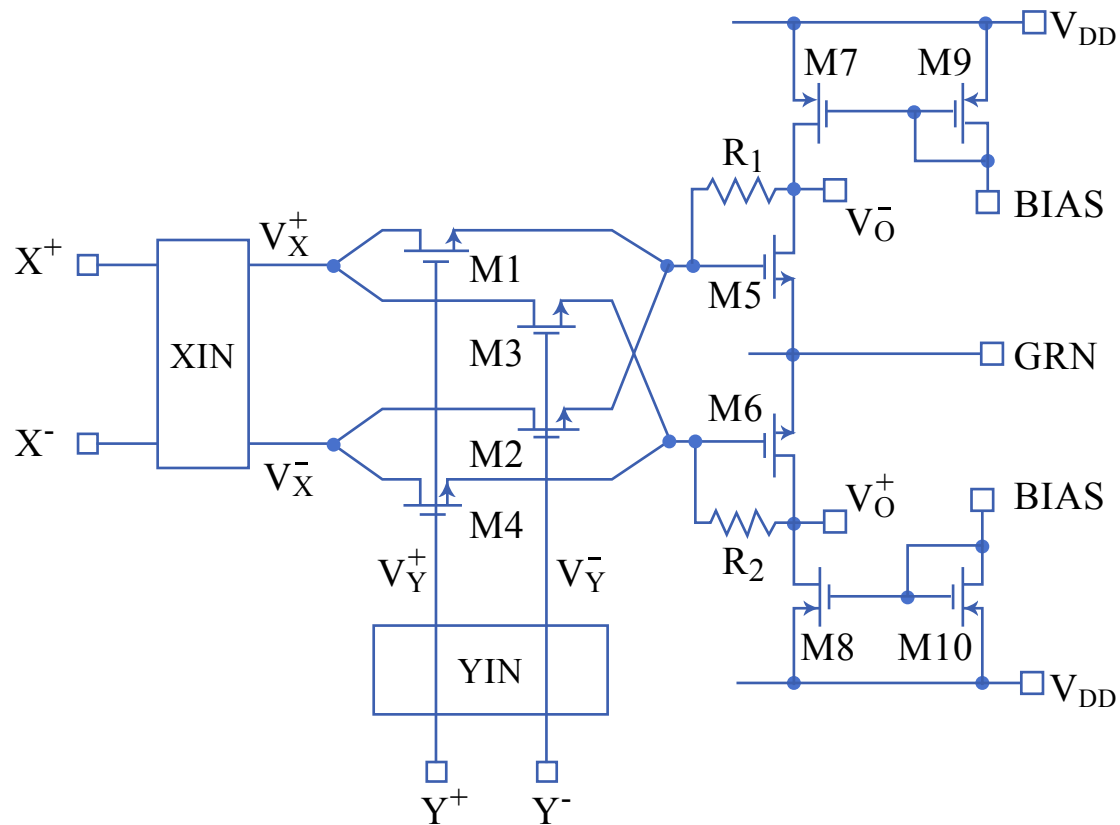

Figure by MIT OCW.

B. Song, "CMOS RF circuits for data communications applications," *IEEE Journal of Solid-State Circuits*, vol. 21, pp. 310 - 317, April 1986.

- Transistors are operated in triode regions
- The product terms cancel out resulting in linear multiplication

CMOS Analog Multiplier Analysis

$$I_1 = K' \left\{ \left(V_{GS} + \frac{v_y}{2} - V_T \right) \left(\frac{v_x}{2} \right) - \frac{1}{2} \left(\frac{v_x}{2} \right)^2 \right\}$$

$$I_2 = K' \left\{ \left(V_{GS} - \frac{v_y}{2} - V_T \right) \left(-\frac{v_x}{2} \right) - \frac{1}{2} \left(-\frac{v_x}{2} \right)^2 \right\}$$

$$I_3 = K' \left\{ \left(V_{GS} - \frac{v_y}{2} - V_T \right) \left(\frac{v_x}{2} \right) - \frac{1}{2} \left(\frac{v_x}{2} \right)^2 \right\}$$

$$I_4 = K' \left\{ \left(V_{GS} + \frac{v_y}{2} - V_T \right) \left(-\frac{v_x}{2} \right) - \frac{1}{2} \left(-\frac{v_x}{2} \right)^2 \right\}$$

$$K' = \mu C_{OX} W / L \quad v_x = V_x^+ - V_x^- \quad v_y = V_y^+ - V_y^-$$

$$\begin{aligned} v_0 &= V_0^+ - V_0^- \\ &= R(I_1 + I_2 - I_3 - I_4) = K v_x v_y \end{aligned}$$

$$K = K' \times R$$

A Highly Linear CMOS Mixer

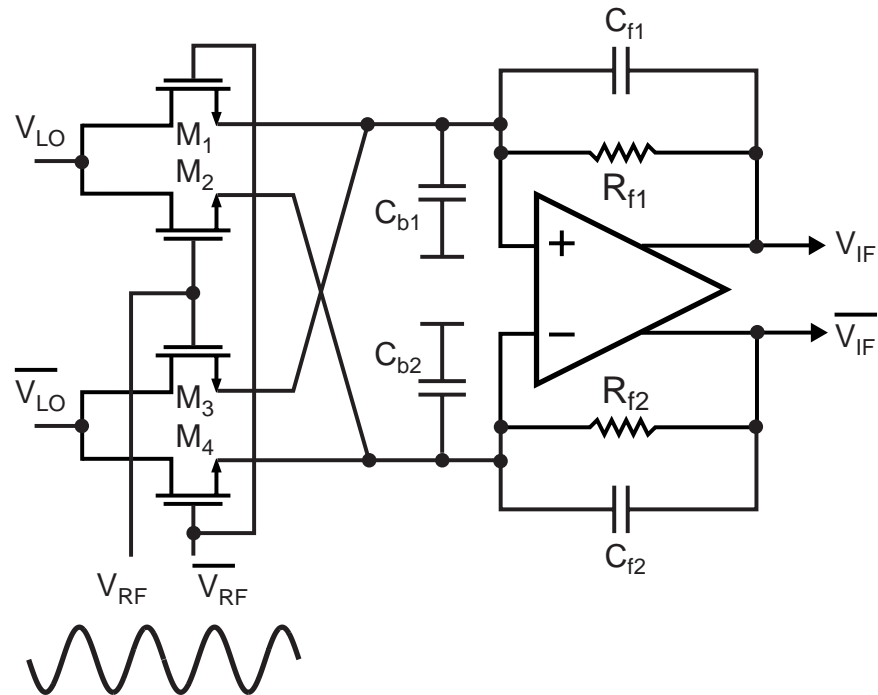

J. Crols and M. S. J. Steyaert, "A 1.5 GHz highly linear CMOS downconversion mixer," *IEEE Journal of Solid-State Circuits*, vol. 30, pp. 736 - 742, July 1995

- Transistors are alternated between the off and triode regions by the LO signal
 - RF signal varies resistance of channel when in triode
 - Large bias required on RF inputs to achieve triode operation
- High linearity achieved, but very poor noise figure

Passive Mixers

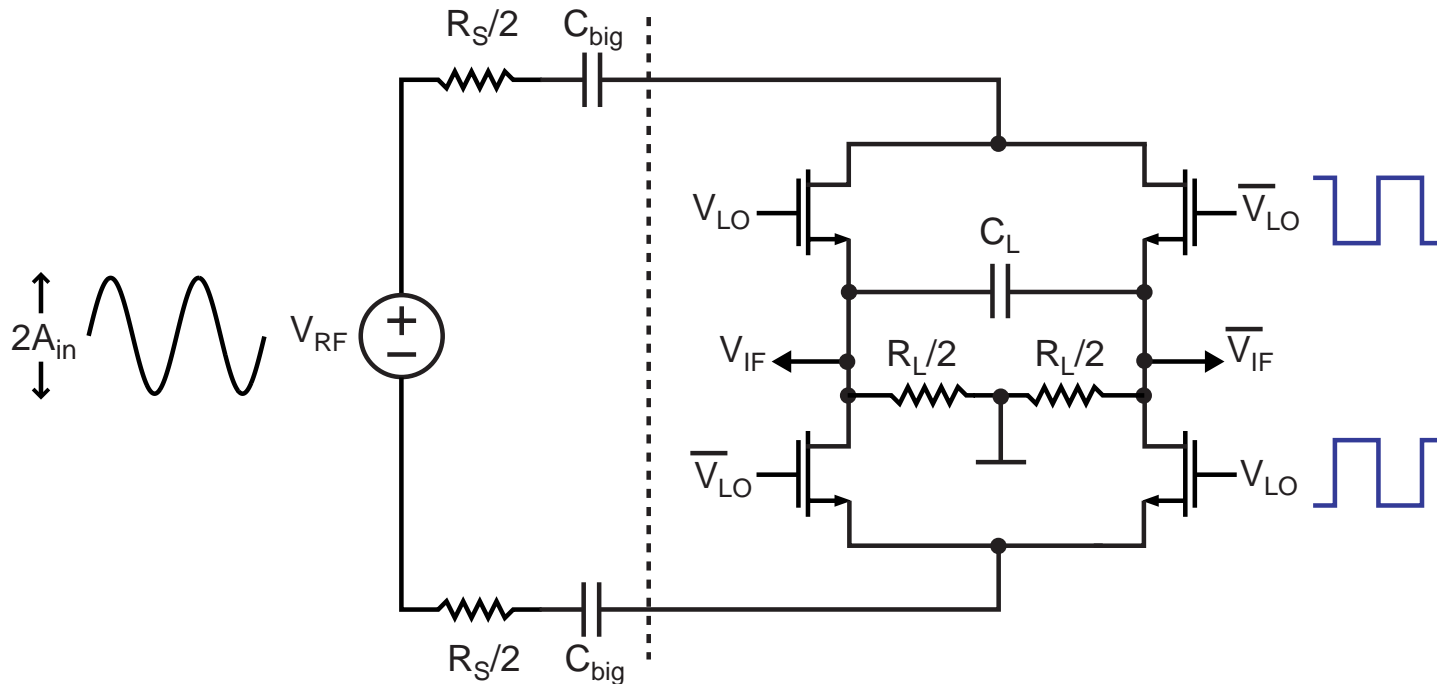

- We can avoid the transconductor and/or op amp
- simply use switches to perform the mixing operation
 - No bias current required allows low power operation to be achieved
- Disadvantage: the RF input is low impedance

Square-Law Mixer

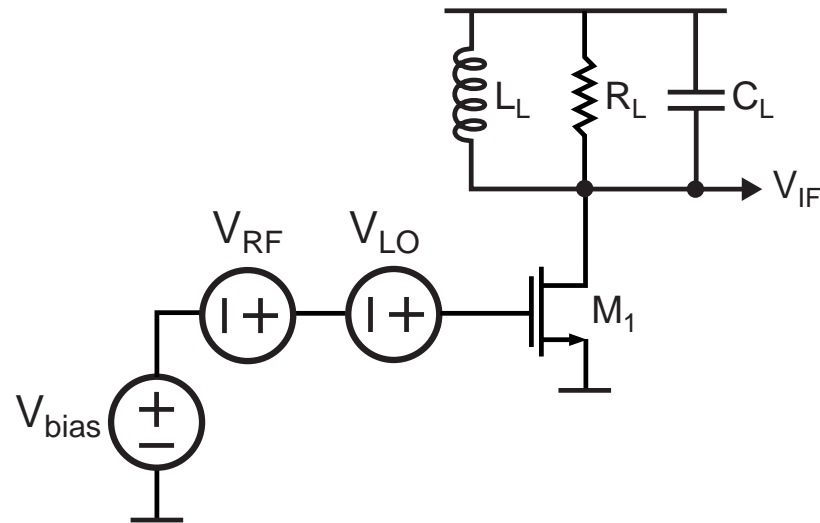

- Achieves mixing through nonlinearity of MOS device
 - Ideally square law, which leads to a multiplication term

$$(V_{RF} + V_{LO})^2 = V_{RF}^2 + 2V_{RF}V_{LO} + V_{LO}^2$$

- Undesired components must be filtered out
- Need a long channel device to get square law behavior (no velocity saturation!)
- Issue – no isolation between LO and RF ports

Alternative Implementation of Square Law Mixer

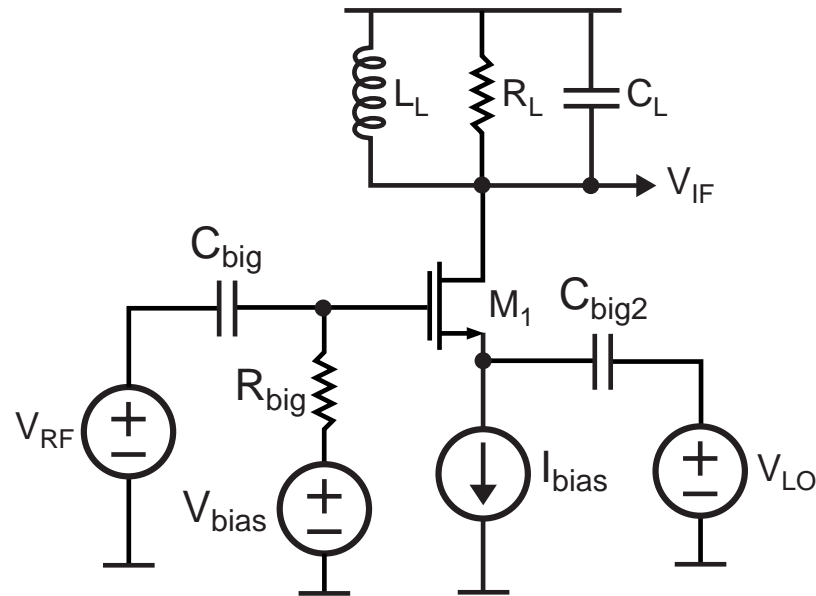

- **Drives LO and RF inputs on separate parts of the transistor**
 - Allows some isolation between LO and RF signals
- **Issue - poorer performance compared to multiplication-based mixers**
 - Lots of undesired spectral components
 - Poorer isolation between LO and RF ports

Flicker Noise in Gilbert-Type Mixer

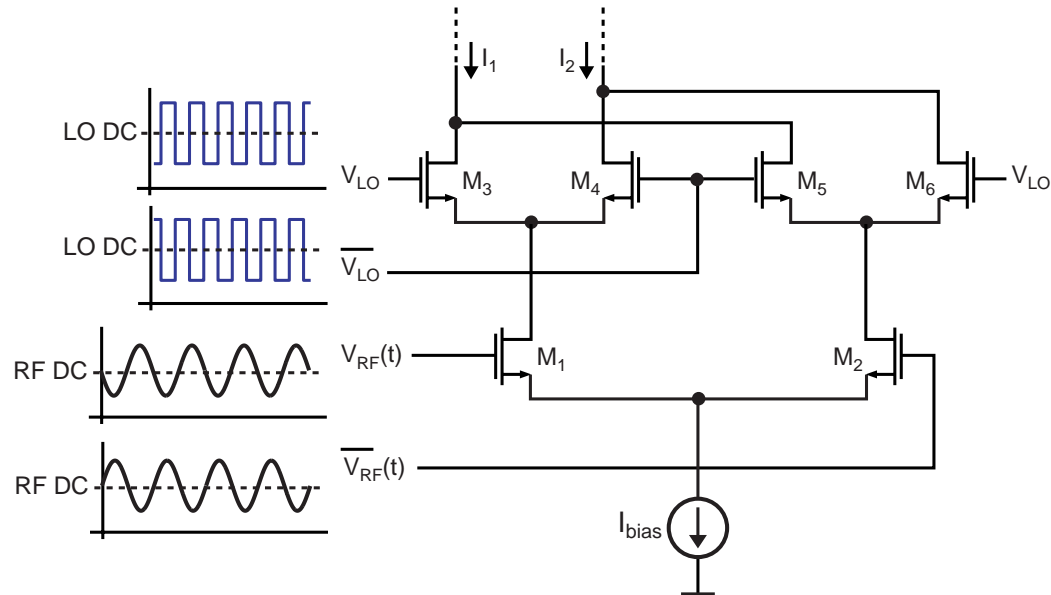

- Let's consider Gilbert-type mixer for direct conversion receivers
- $1/f$ noise in G_m transistors (M_1 and M_2): Up-converted to LO frequency (no issue)
- $1/f$ noise in switches (M_3 - M_6) no effect if LO signal is a square wave
- Typically, the LO output is not a square wave, and has finite slope at the switching instant: $1/f$ noise in M_3 - M_6 modulates the switching threshold of switch pairs!

Flicker Noise Analysis

H. Darabi and J Chiu "A Noise Cancellation Technique in Active RF-CMOS Mixers,"
Digest of Technical Papers, 2005 ISSCC pp544-545.

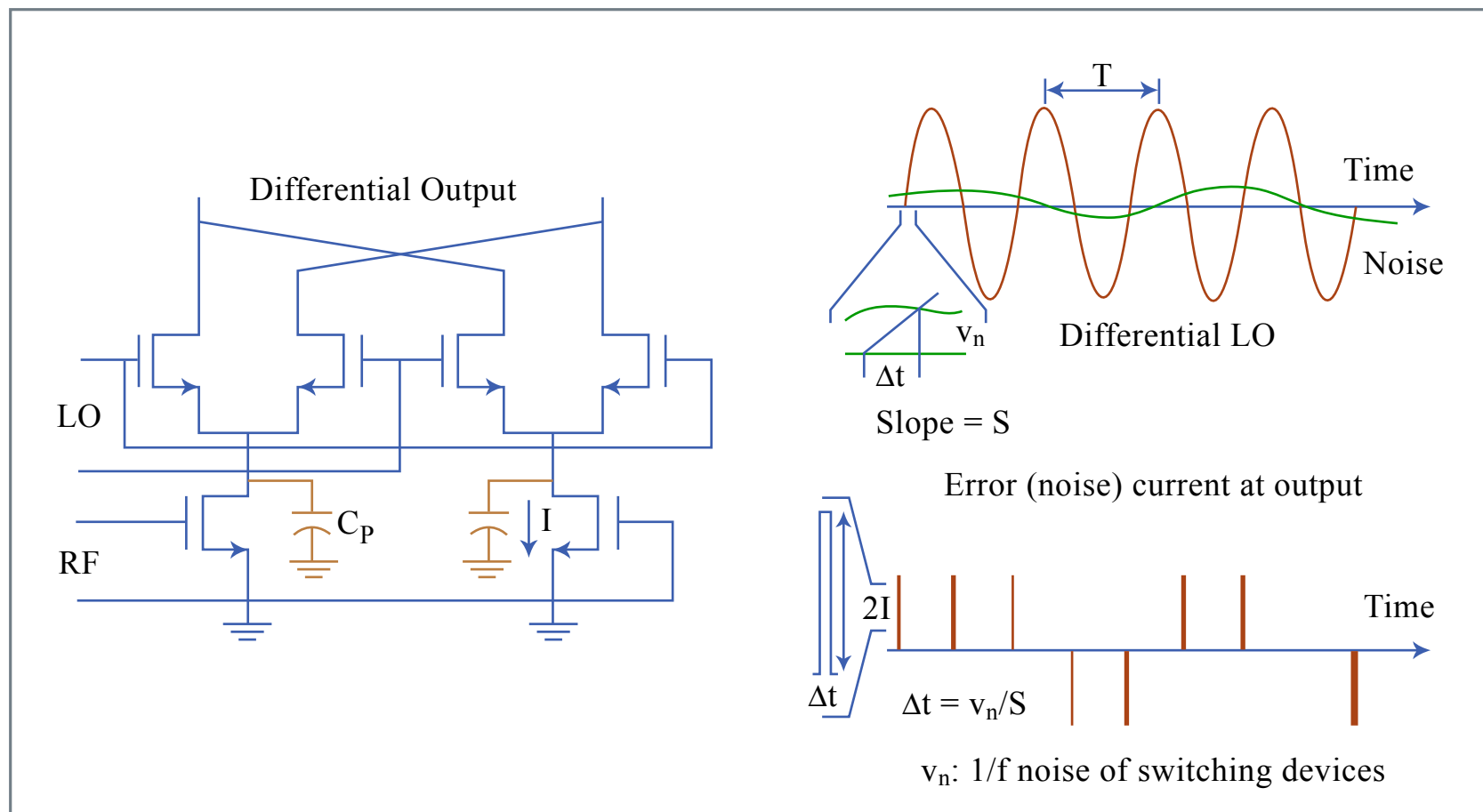

Figure by MIT OCW.

- **1/f noise at the output is proportional to bias current I and inversely proportional to LO slope S**

Flicker Noise Reduction in Gilbert Mixer

- Inject current at the switching moments to reduce current through switching devices

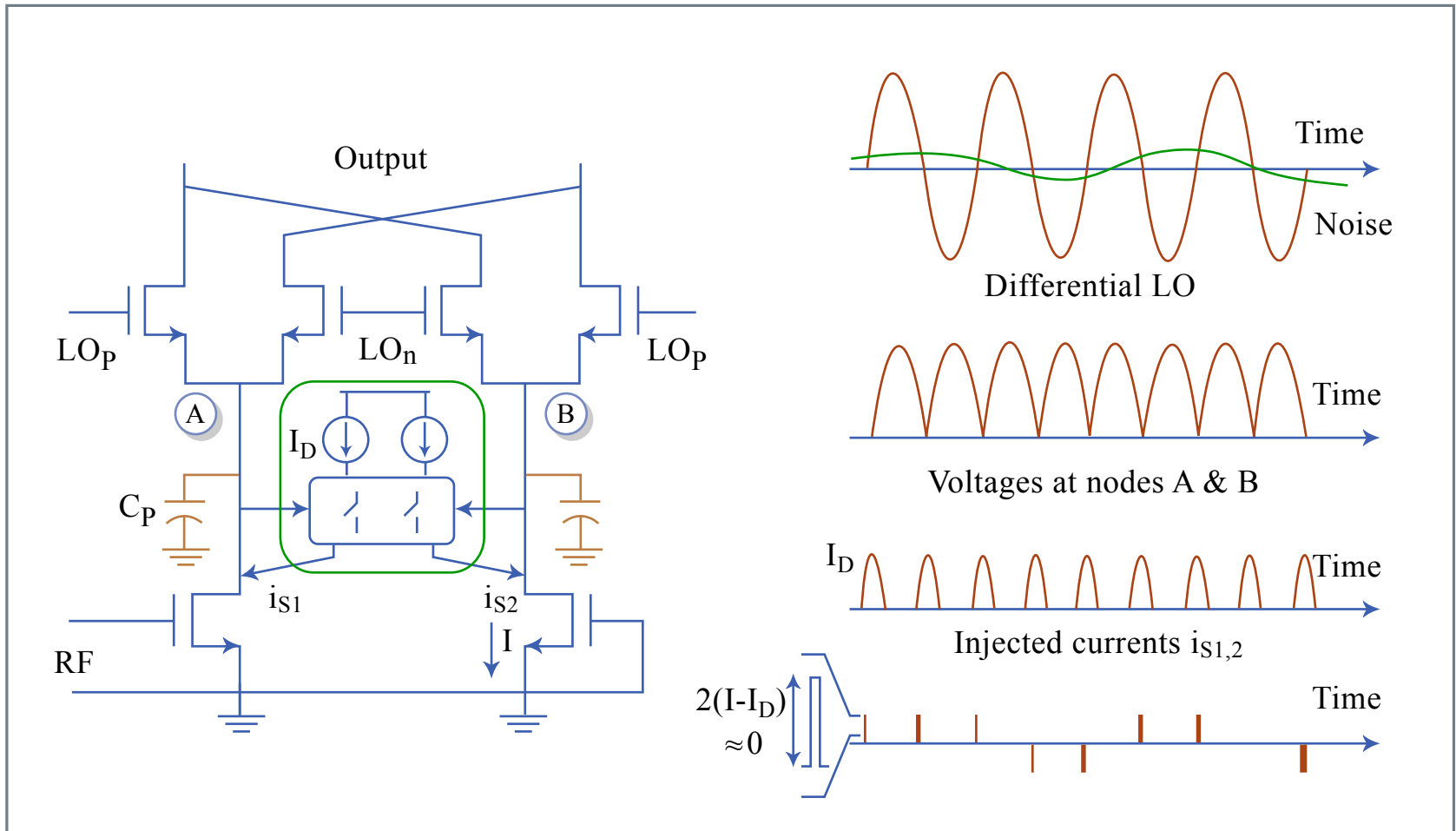

Figure by MIT OCW.

Actual Implementation of Noise Cancellation

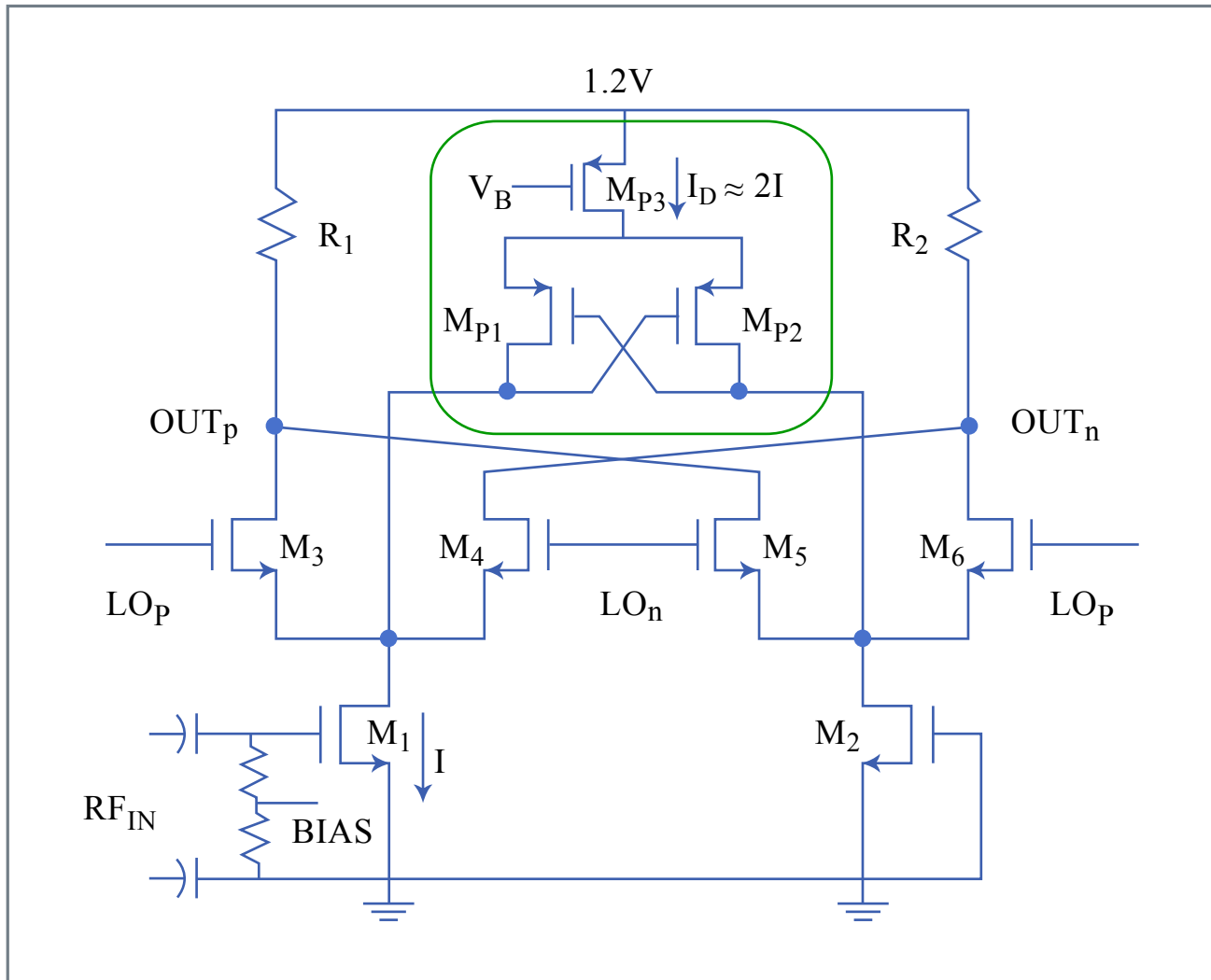
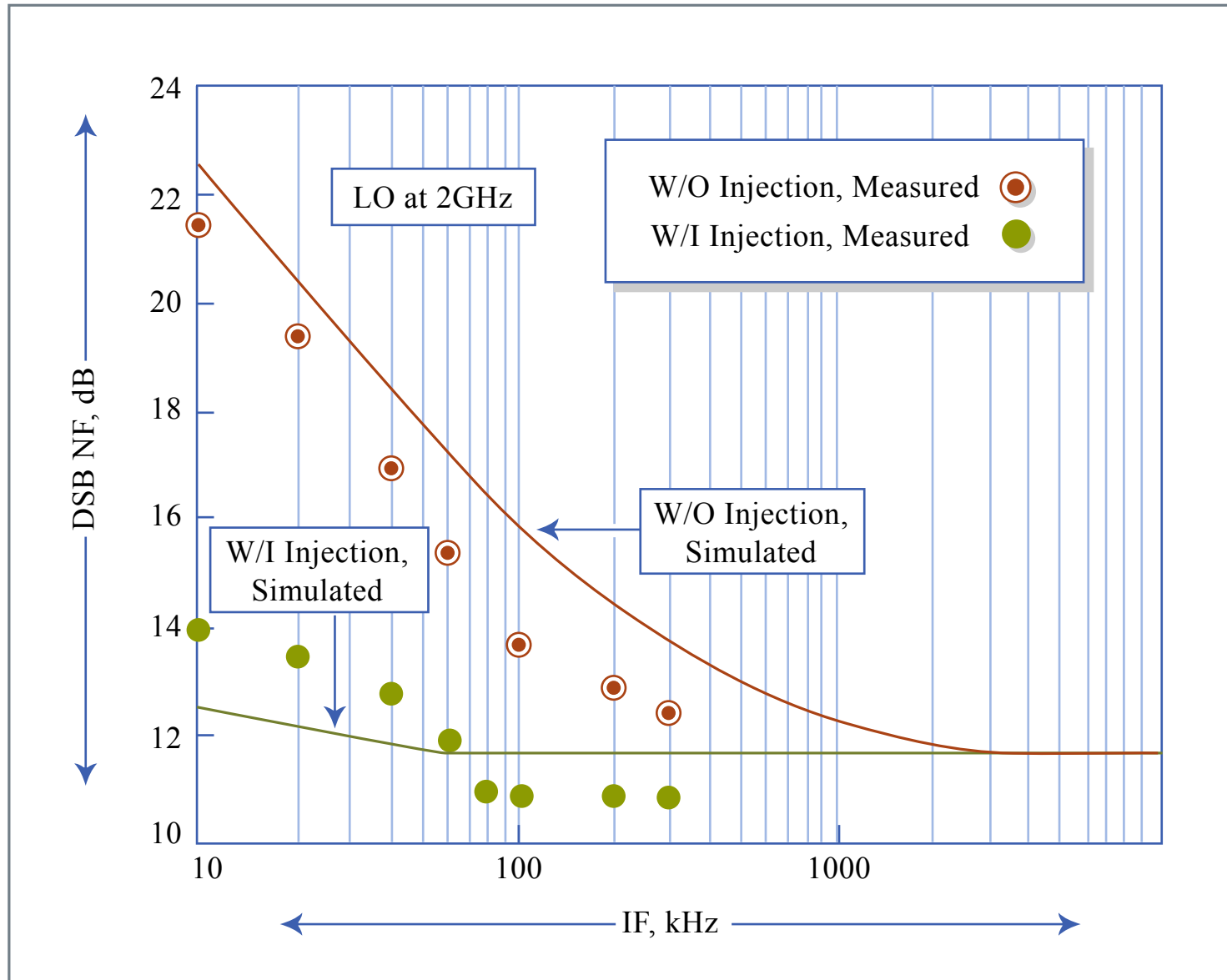

Figure by MIT OCW.

H. Darabi and J Chiu "A Noise Cancellation Technique in Active RF-CMOS Mixers,"
Digest of Technical Papers, 2005 ISSCC pp544-545.

Noise Cancelled Mixer Results



Noise Cancelled Mixer Results Summary (2GHz)

Parameter	MIXER WITH INJECTION		MIXER WITHOUT INJECTION	
	Measured	Simulated	Measured	Simulated
IIP3	10.5dBm	11dBm	10.5dBm	10.8dBm
White NF	11dB	11.8dB	11dB	11.6dB
Voltage Gain	0.5dB	1dB	0dB	0.5dB
Bias Current	2mA	2mA	2mA	2mA
NF at 20kHz	13.5dB	12.3dB	19.5dB	20.4dB
1-dB Compression	-1.5dBm	-0.8dBm	-1.5dBm	-0.8dBm

Figure by MIT OCW.